



An IMCI Company
BIJUR DELIMON
INTERNATIONAL



SINGLINE® PROGRESSIVE

PUMPS, VALVES, CONTROLLERS

BULLETIN SL2800

Contents

Introduction	2
M2500G Series Valves	3-6
PVBM Series Valves	7-8
3000 Series Valves	9-10
U-Blocks and Sureshot Kits	11
M2500G, PVBM & 3000 Accessories	12-14
Remote Zone Valves	15
Multi Purpose Zone Valves	16
GPO Motor Driven Oil Pump Packages	17
Dynamis Maxx Pumps	18
MultiPort II Grease Pump Packages	19
MultiPort I Grease Pump Packages	20
CLP Cartridge Lube Pump	21
CS2000 Central Stations	22
EBP Electric Grease Barrel Pumps	23
TP Air/Hydraulic Operated Pumps	24
T30, T32 Oil/Grease Reservoirs	25
Ordering Info for Complete Air/ Hydraulic Pumps Packages	26
SureMatic Pumps	27
Air Grease Drum Pumps	28
Manual/Mechanical Pumps	29
Lube Point Monitor & DS405	30
SMAC-MAX & SMDC Controls	31
SS2200 & SC400 Controls	32
Timers & Strainers	33
Notes	34

MODULAR
CONSTRUCTION,
EASY INSTALLATION &
MAINTENANCE,
INDIVIDUAL ZONE
CONTROL,
ZINC-NICKEL PLATING

Illustrations and specifications are not binding in detail. Designs are subject to modification and improvement without notice.

Introduction

The series M2500G, 3000 and PVBM Progressive Divider Valve Manifolds distribute and proportion incoming oil or grease to bearing points. A typical divider valve manifold consists of an inlet section, three to ten valves and an end section. One assembly can serve up to a maximum of 20 lubrication points. Individual divider valve blocks have a discharge piston and built-in outlet check valves. Blocks are offered in various output sizes. The discharge capacity of a block is determined by varying the piston diameter in the valve block.

Twin valve blocks have two outlets located at each end of the assembly and supply rated discharge from each of the two outlets during one complete valve cycle. Single outlet blocks have one end outlet plugged and supply twice the rated output to the open outlet. External cross porting of adjacent valves can be achieved with a cross port kit to combine outputs.

PROGRESSIVE DIVIDER VALVE OPERATING SEQUENCE

Individual valve blocks operate in a "Progressive" sequence. During operation, the piston within the block must complete a full discharge cycle before another piston begins operation. As long as lubricant is supplied under pressure to the inlet section of the divider, manifold valve blocks will continue to operate in a progressive manner.

When lubricant flow is interrupted to the inlet block, piston movement stops. When flow resumes, piston movement commences at the same point in the discharge cycle. Feed lines deliver lubricant from the valve block to individual lube points. Should a discharge line become blocked, it will stop all the valves operating. Indicators are available to alert a blockage.

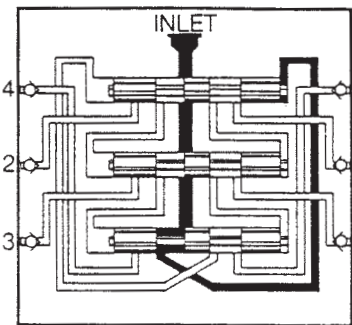

FIGURE 1

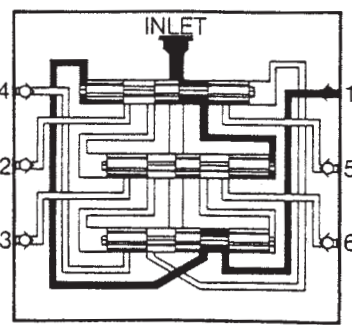

FIGURE 2

FIGURE 1: The inlet is connected to all piston chambers with only one piston free to move at any one time. With all pistons at the far right, lubricant flows against the right end of piston 1.

FIGURE 2: Lubricant flow moves piston 1 from right to left, displacing lubricant through passages to outlet 1. The shifting of piston 1 moves the lubricant flow against the right side of piston 2.

FIGURE 3: Lubricant flow moves piston 2 from right to left, displacing lubricant through outlet 2. The shifting of piston 2 moves the lubricant flow against right side of piston 3.

FIGURE 4: Lubricant flow shifts piston 3 from right to left displacing lubricant through outlet 3. The shifting of piston 3 moves the lubricant flow against right side of piston 1 (This would continue for as many valves mounted: 3-10 section).

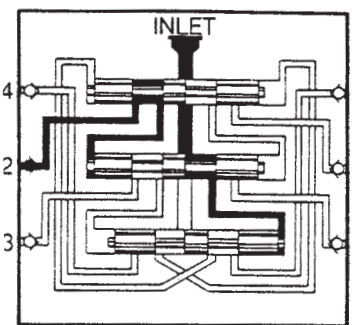

FIGURE 3

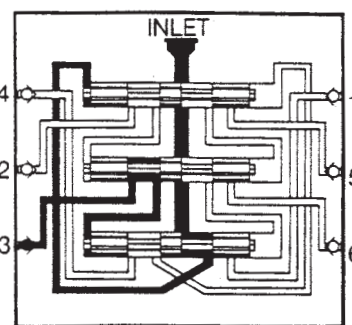

FIGURE 4

Lubricant flow on left side of piston 1 begins the second cycle which shifts pistons from left to right, displacing lubricant through outlets 4, 5 and 6 of the valve.

M2500G Series

The M2500G Series valve manifolds are the principal components of a Single Line central lubricating system. The modular construction makes the system easy to install, and can be modified and maintained without removing any tubing. Operation of all valves in the system can be monitored by a single cycle indicator switch. Up to 20 bearings can be lubricated from one manifold assembly and up to 20 manifolds can be included in a system.

Zone control components can be used to build a system of any size and can be divided into individually controlled and monitored zones. This permits varied cycle times, rapid trouble-shooting and easy maintenance.

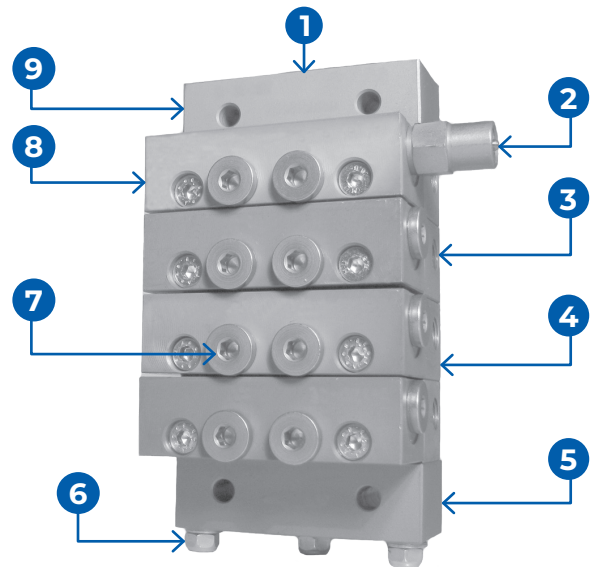

M2500B4G - 4 Section Valve Assembly

FEATURES THAT MAKE THE DIFFERENCE

- VITON O-rings standard to protect against high heat & synthetic lubricants.
- Form, fit and functional interchangeable with all major competitive brands.
- NPSF or BSPP - standard.
- Integral or in-line solenoid valve for zone control.
- Easy to assemble and replace valves without removing tube.
- Operating pressures to 5,800 psi.
- 0.005 to 0.080 cubic inch discharge volumes.
- Zinc-Nickel plating- 1000 hour salt spray.
- Three to Ten section valve manifolds available.

M2500G SPECIFICATIONS

Max Operating Pressure	5800 psi (400 bar)
Min Operating Pressure	300 psi (20 bar)
Discharge Per Cycle	0.005 (0.08cc) to 0.080 (1.31cc)
Lubricant	Oil to NLGI #2 Grease
Seals	VITON O-rings (70 durometer)
Max. Temperature	350°F (163°C)
Material	Steel (Zinc-Nickel Plated)

TORQUE SPECIFICATIONS

Tie Rod Nuts	5-8 foot pounds
Outlet Port Fitting	8-9 foot pounds
Piston Enclosure Plugs	12-15 foot pounds
Valve Mounting Screws	8-9 foot pounds

Item #	Description	Item #	Description
1	Lube Inlet Port	6	Tie Rods
2	Cycle Indicator Pin	7	Alternate Outlet Port
3	Discharge Ports	8	Valve Section
4	Base Section	9	Inlet Section
5	End Section		

DIVIDER VALVE ASSEMBLY (WEIGHT)

Divider Valve Assembly	Approximate Net Weight
3 Section Divider	6.2 lb (2.8 kg)
4 Section Divider	7.6 lb (3.5 kg)
5 Section Divider	9.1 lb (4.1 kg)
6 Section Divider	10.5 lb (4.8 kg)
7 Section Divider	11.9 lb (5.4 kg)
8 Section Divider	13.4 lb (6.1 kg)
9 Section Divider	14.8 lb (6.7 kg)
10 Section Divider	16.2 lb (7.4 kg)

Refer to the following documents for more info:
+ Datasheet #35821: M2500G Divider Valves

M2500G Series – Parts

M2500G DIVIDER VALVE ASSEMBLIES CONSIST OF AN INLET SECTION, BASE SECTIONS (3-10), END SECTION AND VALVES

Valve Size	Discharge Cu. In. (cc)		Valve Sections					
	Twin Outlet	Single Outlet	Twin Outlet			Single Outlet		
			Standard	With STD* Cycle Pin	With Prox** Cycle Pin	Standard	With STD* Cycle Pin	With Prox** Cycle Pin
5	0.005 (0.08)	0.010 (0.16)	MCVA250105TG	--	--	MCVA250105SG	--	--
10	0.010 (0.16)	0.020 (0.33)	MCVA250110TG	--	--	MCVA250110SG	--	--
15	0.015 (0.25)	0.030 (0.49)	MCVA250115TG	--	--	MCVA250115SG	--	--
20	0.020 (0.33)	0.040 (0.66)	MCVA250120TG	MCVA250120TPG	M25U20TPG	MCVA250120SG	MCVA250120SPG	M25U20SPG
25	0.025 (0.41)	0.050 (0.82)	MCVA250125TG	MCVA250125TPG	M25U25TPG	MCVA250125SG	MCVA250125SPG	M25U25SPG
30	0.030 (0.49)	0.060 (0.98)	MCVA250130TG	MCVA250130TPG	M25U30TPG	MCVA250130SG	MCVA250130SPG	M25U30SPG
35	0.035 (0.57)	0.070 (1.15)	MCVA250135TG	MCVA250135TPG	M25U35TPG	MCVA250135SG	MCVA250135SPG	M25U35SPG
40	0.040 (0.66)	0.080 (1.31)	MCVA250140TG	MCVA250140TPG	M25U40TPG	MCVA250140SG	MCVA250140SPG	M25U40SPG

Note: Valve sections include VITON O-rings and mounting screws. MCVA2501BPG bypass valve with VITON O-rings is available (can be used with a four section divider valve assembly or larger-requires at least three working sections.)

*Standard 17324/33583 switch can be fitted. ** Prox 66925 series switches can be fitted. (see page 13 for options)

DIVIDER BLOCK COMPONENTS INLET SECTION

Inlet Type	Part Number	
Standard	1/4-18 NPSF	MCI2504BG
	1/4-19 BSPP	MCI2504CG
Zone-oil*	1/4-19 BSPP	MCI2504ZC3G
Zone-grease*	1/4-18 NPSF	37500B
	1/4-19 BSPP	37500C

*Note: Select Applicable Control Valve (38152 or MCZ2503) from page 6

VALVE BASE SECTION

Description	Part Number
1/8-27 NPSF discharge ports	MCBA2502BG
1/8-28 BSPP discharge ports	MCBA2502CG

Note: Includes integral check valves, VITON O-rings

END SECTION

Description	Part Number
Includes VITON O-rings	MCEA2503G
Includes 1/8" NPT port for grease fitting	37484

Notes:
See page 12 for cross-port and high pressure indicators.
See page 13-14 for cycle switch and cables.

DIMENSIONAL SCHEMATICS

Number of Sections	A	B
3	3.58" (91mm)	4.52" (115mm)
4	4.50" (114mm)	5.44" (138mm)
5	5.42" (138mm)	6.36" (162mm)
6	6.34" (161mm)	7.28" (185mm)
7	7.27" (185mm)	8.20" (208mm)
8	8.19" (208mm)	9.13" (232mm)
9	9.11" (231mm)	10.04" (255mm)
10	10.03" (235mm)	10.97" (279mm)

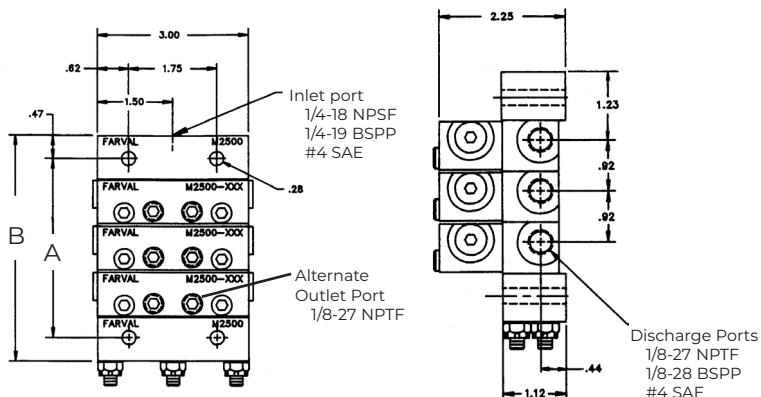

TIE ROD KITS

Tie Rod Kits include 3 tie rods & 3 nuts.

Number of Sections	Part Number	Number of Sections	Part Number
3	MCRK25053G	7	MCRK25057G
4	MCRK25054G	8	MCRK25058G
5	MCRK25055G	9	MCRK25059G
6	MCRK25056G	10	MCRK250510G

M2500G Series – Assembly Ordering Instructions

Completely assembled Single Line M2500G Modular Valve Manifolds can be ordered as follows:

First, select the manifold base assembly from the table. This assembly includes the inlet section, valve base sections, end section, tie rods, nuts and o-rings; the valve sections are installed on it. Each valve section and bypass section requires a base section, and every manifold must have at least 3 operating valve sections.

Next, specify the valves, bypass sections and accessories. Begin at the first section after the inlet and continue towards the end section. Separate each entry with a slash:

1 2 3 4
/ - - - , - - - - , - - - -

1 - VALVE/SIZE (05, 10, 15, ETC.)

- T - Twin
- S - Single (no outlet)
- SL - Single (outlet to left)
- SR - Single (outlet to right)

2 - OUTLETS

3 - OPTIONAL ACCESSORIES

- PP - Pin-type pressure indicator*
- CIP - Cycle Indicator PIN
- CS - Cycle Switch**
- CP - Crossport

Note:

* Provide part number (See page 10).

** Specify which cycle switch model (See page 13).

Add L or R to the above codes to specify the location of each accessory.

4 - OTHER ACCESSORIES (AS REQUIRED)

Note: Zone control valves are ordered as separate items as shown on pages 11 and 12. Omit the mounting style code. Other accessories such as electrical cables must also be ordered as separate items.

EXAMPLE

- Ordering code for complete assembly. The complete part number for an M2500G manifold with the following specifications would be:

M2500B5G/05SR/10S,CPR/10SL/BP/30T

5 section manifold, NPSF ports, standard inlet	M2500B5G
05 single, outlet right, visual indicator to left	05SR
10 single, no outlet, crossport to right	10S, CPR
10 single, outlet left	10SL
Bypass section	BP
30 twin, outlets left and right	30T

Inlet Type	Number of Sections	Discharge Ports	
		1/8-27 NPSF	1/8-28 BSPF
Standard	3	M2500B3G	M2500C3G
	4	M2500B4G	M2500C4G
	5	M2500B5G	M2500C5G
	6	M2500B6G	M2500C6G
	7	M2500B7G	M2500C7G
	8	M2500B8G	M2500C8G
	9	M2500B9G	M2500C9G
	10	M2500B10G	M2500C10G

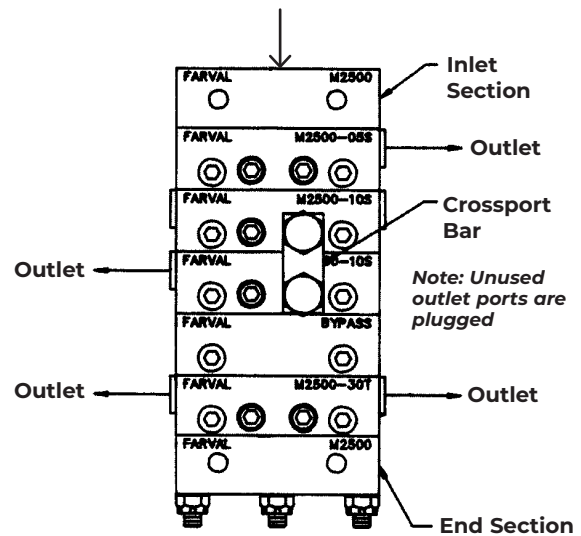

Provide basic sketch similar to above when ordering.

Note: Only M2500B4G and larger assemblies can have a "BP" section, all assemblies must have minimum of 3 working sections.

M2500G Series – Zone Valves

ZONE CONTROL VALVES

Zone Control Valves are typically used to isolate certain sections on a machine to receive more/less frequent lube cycles.

STYLE

- 38152M series operating pressure up to 4350 psi.
- MCZ2503B series for all grease systems operating up to 3000 psi.

INSTALLATION

- In the inlet section of M2500G series manifold (see page 4 for zone inlets).
- As a stand alone component mounted in a remote location (see page 15).

ELECTRICAL

- 115 Volt AC (50 or 60 Hz)
- 24 Volt DC
- Class H Coils

CONNECTORS

- Standard 1/2 inch conduit with insulated 18 AWG leads
- Automotive 3 pin connector accepts Brad harrison Mini-Change or Crouse Hinds Mini-Line connectors. Conforms to ANSI B93.55M
- Hirschmann connector/DIN

PORT TYPES

- Integral valves: 1/4-18 NPSF or 1/4-19 BSPP on inlet
- Remote valves: #6 SAE or 1/4-18 NPTF on inlet and outlet

ELECTRICAL SPECIFICATIONS

Amp Draw	MCZ2501F	MCZ2501A	MCZ2503B
115 AC	.21 amp	.21 amp	.17 amp
24V DC	.90 amp	.90 amp	.83 amp

HOW TO ORDER GREASE VALVES

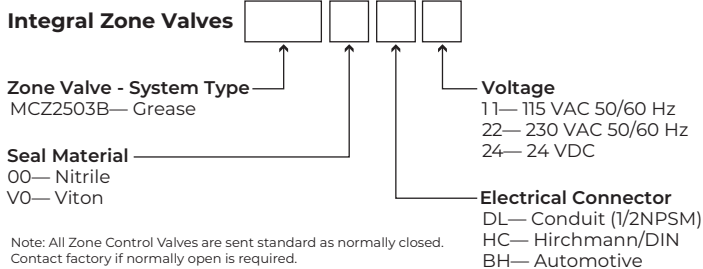

HOW TO ORDER OIL VALVES

	P.N.	VOLTAGE	SEALS	ELEC CONN
OIL	38152M115	24VDC	VITON	Hirschmann/DIN
	38152M116	115VAC	VITON	Hirschmann/DIN
	38152M117	230VAC	VITON	Hirschmann/DIN

M2500G Integral Oil or Grease

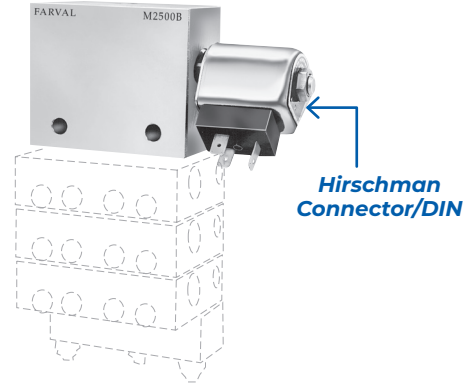

M2500G VALVE MANIFOLDS WITH INTEGRAL ZONE CONTROL

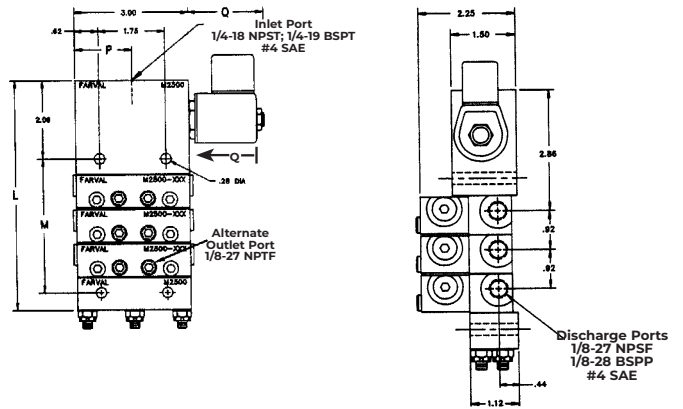

Lubricant	P	Q
Oil Service (38152 Series)	1.50	82mm
Grease Service (MCZ2503 Series)	2.25	2.35

DIMENSIONS

# of Sections	M		L	
	Inch	MM	Inch	MM
3	3.58	91	7.03	179
4	4.50	114	7.95	202
5	5.42	138	8.97	228
6	6.34	161	9.80	249
7	7.27	185	10.72	272
8	8.19	208	11.64	296
9	9.11	231	12.56	319
10	10.03	255	13.48	342

PVBM Series

The PVBM Divider Valve accurately meters and dispenses lubricant to as many as 20 outlet lines at operating pressures up to 5076 psi. Output volumes are fixed at 0.20cc (0.012 cu. in.) per cycle but can be combined with other outlets by using appropriate fittings for larger outputs. Valves have a cycle indicator pin to provide visual confirmation of system operation. In addition the cycle pin can be fitted with a switch to provide electrical feedback to a system controller.

PROGRESSIVE DIVIDER VALVE OPERATING SEQUENCE

Operational sequence of a PVBM Divider Valve is defined as “progressive,” meaning that each valve segment completes its piston stroke, discharging a positive volume of lubricant to the point it serves before the following valve segment operates. As long as lubricant is supplied under pressure to the inlet of the divider valve, these segments will continue to operate in a progressive manner. The divider valves will always follow a constant discharge pattern. When lubricant flow ceases, the pistons will stop. Whenever flow resumes, the pistons will start again at the same point in the discharge cycle.

FEATURES

- + Flexible design allows for on-site configurations
- + Valves available in sizes ranging from 6 to 20 outlets
- + Positive displacement discharge
- + One switch monitors complete system
- + Valves are corrosion resistant

PVBM SERIES SPECIFICATIONS

Max Operating Pressure	5076 psi (350 bar)
Min Operating Pressure	145 psi (10 bar)
Discharge Per Cycle/Outlet	0.20cc (0.012 cu.in.)
Lubricant	Oil to NLGI #2 Grease
Seals	Non-asbestos composition with steel core
Max. Temperature	-4 °F to 248 °F (-20 °C to 120 °C) without pin -13 °F to 176 °F (-25 °C to 80 °C) with pin
Material	Steel (Zinc Nickel Plated)

TORQUE SPECIFICATIONS

Steel Outlet Fittings & Plugs	18Nm +/-2 Nm
Brass Outlet Fittings	10Nm +/-2 Nm

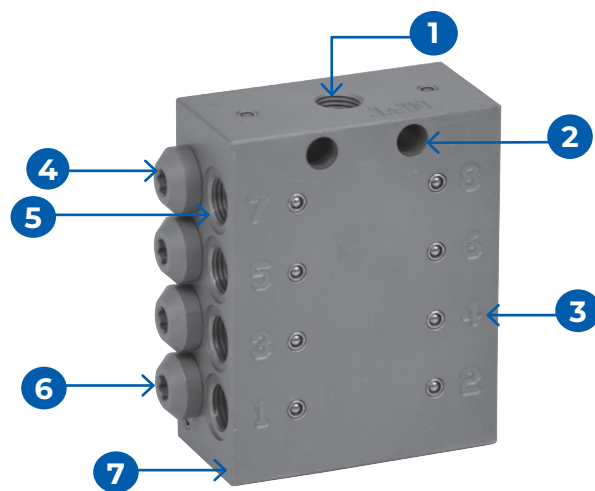

Item #	Description
1	1/8" NPT Lube Inlet
2	7mm Ø Mounting holes
3	Numbered Outlets
4	Piston Plugs

Item #	Description
5	Outlets (6-20)* Require special PVB specific fittings
6	Available with cycle pin
7	Zinc Nickel Finish

DIVIDER VALVE ASSEMBLY (WEIGHT)

Divider Valve Assembly	Approximate Net Weight
6 Outlet Divider	1.7 lb (0.77 kg)
8 Section Divider	2.2 lb (1.0 kg)
10 Section Divider	2.6 lb (1.18 kg)
12 Section Divider	3.0 lb (1.36 kg)
14 Section Divider	3.5 lb (1.59 kg)
16 Section Divider	4.0 lb (1.81 kg)
18 Section Divider	4.2 lb (1.91 kg)
20 Section Divider	5.0 lb (2.27 kg)

HOW TO ORDER PVBM SERIES DIVIDER VALVES

Number of Outlets	Divider Part Number
	With Cycle Pin
06	PVBM06-001
08	PVBM08-001
10	PVBM10-001
12	PVBM12-001
14	PVBM14-001
16	PVBM16-001
18	PVBM18-001
20	PVBM20-001

Refer to the following documents for more info:
+ Datasheet #35635: PVBM Divider Valves

PVBM Series

PVBM OUTLET FITTINGS & PLUGS

	Description	Part #
Compression	3/16" O.D. TBG outlet fittings with check valve	35360
	6mm O.D. TBG outlet fittings with check valve	23301-1
Quick Connect	1/4" O.D. TBG outlet fittings with check valve	AR5116
	4mm O.D. TBG outlet fittings with check valve	35895
	6mm O.D. TBG outlet fittings with check valve	AR5195
Adapter*	1/8" O.D. NPT(F) outlet fitting with check valve	29076
Plugs	Closure plug – "b" porting (singling)	74161-1851
	Clamping ring – "b" porting (singling)	23292
	Closure plug – "c" porting	74161-5741
	Copper seal – "c" porting	72712-1094

* Note: Allows use of standard fittings or hose adapters.

DIVIDER VALVE DIMENSIONS

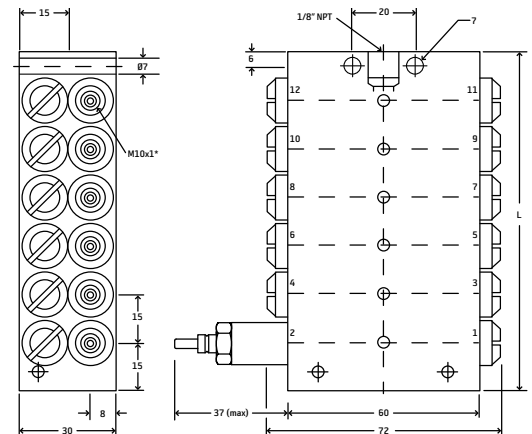

PVBM ACCESSORIES

Description	Part Number
PVB bracket	35417
1/4-20 Grade 8 – 1.625" bolt	35642
1/4-20 Grade 8 – Nylon locknut	35539
Proximity cycle switch with LED (NPN) (Use with SMDC controller, Multiport II)	66925S003*
Proximity cycle switch with LED (PNP) (Use with pCo controller)	66925-1311*
Cable, Straight, 10 meters long	76928-2863
Cable, 90°, 10 meters long	76928-2833
Field Wire-able Connector, Straight, 5-pole	23694
Field Wire-able Connector, 90°, 5-pole	23694-1

* Use with cable part #76928-2863 or #76928-2833

DIMENSIONAL SCHEMATICS

# of Outlets	L
6	2.34" (59.4mm)
8	2.92" (74.2mm)
10	3.50" (89.0mm)
12	4.08" (103.7mm)
14	4.66" (118.5mm)
16	4.66" (118.5mm)
18	5.25" (133.3mm)
20	5.83" (148.1mm)

PVBM 12 OUTLET

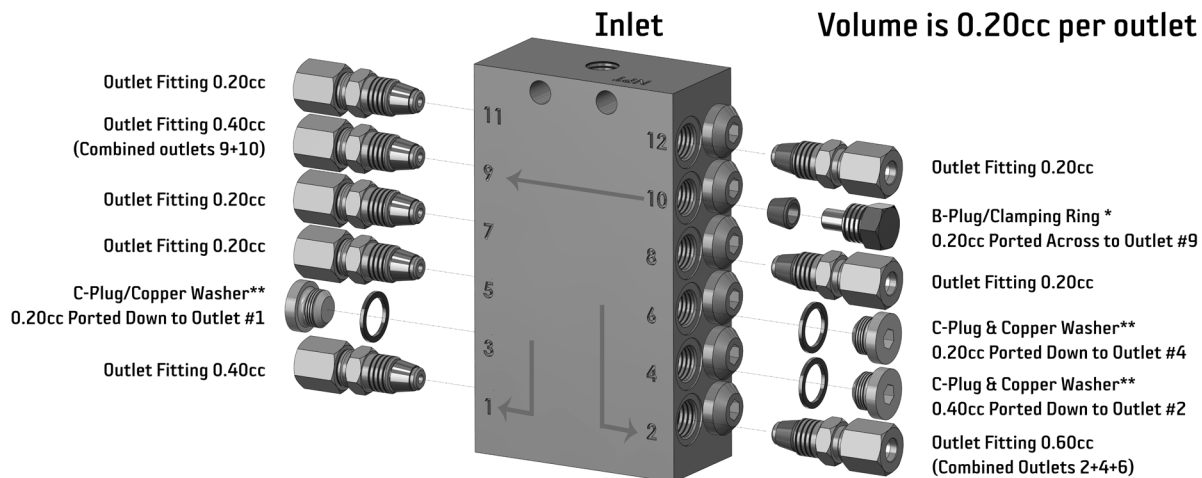

** Note: C-Plugs port volume down adjacent outlet away from the inlet. C-Plugs cannot be used in outlets 1 or 2.

* Note: B-Plugs port across

3000 Series

The Series 3000 Progressive Divider Valve manifold distributes and proportions incoming oil or grease to bearing points. A typical divider valve manifold consists of an inlet section, three to ten valves and an end section. One assembly can serve up to a maximum of 20 lubrication points.

Individual divider valve blocks have a discharge piston and built-in outlet check valves. Blocks are offered in six output sizes. The discharge capacity of a block is determined by varying the piston diameter in the valve block.

Twin valve blocks have two outlets located at each end of the assembly and supply rated discharge from each of the two outlets during one complete valve cycle. Single outlet blocks have one end outlet plugged and supply twice the rated output to the open outlet. External cross-porting of adjacent valves can be achieved with a cross-porting kit to combine outputs.

PROGRESSIVE DIVIDER VALVE OPERATING SEQUENCE

Individual valve blocks operate in a “progressive” sequence. During operation, the piston must complete a full discharge cycle before another piston begins operation. As long as lubricant is supplied under pressure to the inlet section of the divider, valve blocks will continue to operate in a progressive manner.

When lubricant flow is interrupted to the inlet block, piston movement stops. When flow resumes, piston movement commences at the same point in the discharge cycle. Feed lines deliver lubricant from the valve block to individual lube points. Should a discharge line become blocked, it will stop all the valves operating. Indicators are available to alert a blockage.

3000 SERIES SPECIFICATIONS

Max. Operating Pressure	3000 psi (207 BAR)
Min. Operating Pressure	300 psi (20 BAR)
Discharge Per Cycle	0.025 (0.41cc) - 0.300 (4.92cc)
Lubricants	Oil to NLGI #2 grease
Seals	Plated steel with bounded Viton® seals
Max. Temperature	350°F (163°C)
Material	Steel (zinc plated)

TORQUE SPECIFICATIONS

Tie Rod Nuts	72-78 inch pounds
Outlet Port Fitting	72-96 inch pounds
Piston Enclosure Plugs	48 foot pounds

Refer to the following documents for more info:
+ Datasheet #36709: 3000 Divider Valves

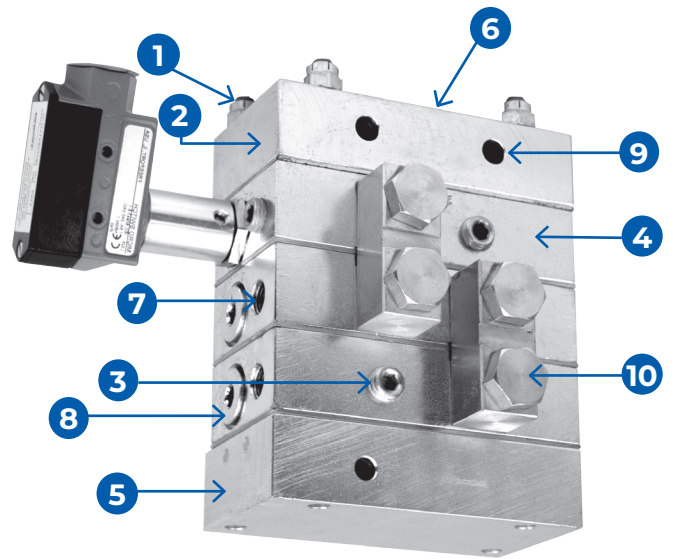

Item	Description	Item	Description
1	Tie Rods	6	3/8 NPSF Lube Inlet
2	Inlet Section	7	1/4 NPSF Lube Outlet
3	1/4 NPSF Alternate Outlet Ports	8	Piston Enclosure Plugs
4	Valve Sections	9	0.406 MTG Hole X 2 (Inlet) 0.406 MTG Hole X 1 (End)
5	End Section	10	Cross-port

DIVIDER VALVE ASSEMBLY (WEIGHT)

Assembly P.N.	Divider Description	Approximate Net Weight	
30013	3 section	22 lbs	9.98 kg
30014	4 section	27 lbs	12.24 kg
30015	5 section	32 lbs	14.52 kg
30016	6 section	37 lbs	16.78 kg
30017	7 section	42 lbs	19.05 kg
30018	8 section	47 lbs	21.32 kg
30019	9 section	52 lbs	23.57 kg
300110	10 section	57 lbs	25.86 kg
300137	3 sec w/ pin	27 lbs	12.24 kg
300147	4 sec w/ pin	32 lbs	14.52 kg
300157	5 sec w/ pin	37 lbs	16.78 kg
300167	6 sec w/ pin	42 lbs	19.05 kg
300177	7 sec w/ pin	47 lbs	21.32 kg
300187	8 sec w/ pin	52 lbs	23.57 kg
300197	9 sec w/ pin	57 lbs	25.86 kg
3001107	10 sec w/ pin	62 lbs	28.12 kg
300138	3 sec w/ pin & switch	28 lbs	12.70 kg
300148	4 sec w/ pin & switch	33 lbs	14.97 kg
300158	5 sec w/ pin & switch	38 lbs	17.24 kg
300168	6 sec w/ pin & switch	43 lbs	19.50 kg
300178	7 sec w/ pin & switch	47 lbs	21.32 kg
300188	8 sec w/ pin & switch	53 lbs	24.04 kg
300198	9 sec w/ pin & switch	58 lbs	26.31 kg
3001108	10 sec w/ pin & switch	63 lbs	28.58 kg

3000 Series

3000 DIVIDER VALVE ASSEMBLIES CONSIST OF AN INLET SECTION, SEVERAL VALVE SECTIONS (3-10) AND AN END SECTION

Valve Size	Discharge cu. in. (cc)		Valve Section					
	Twin Outlet	Single Outlet	Twin Outlet			Single Outlet		
			Standard	W/ Cycle Pin	W/ Cycle SW	Standard	W/ Cycle Pin	W/ Cycle SW
25	.025 (.41)	.050 (.82)	300025	N/A	N/A	300025X	N/A	N/A
50	.050 (.82)	.100 (1.64)	300050	3000507	3000508	300050X	3000507X	3000508X
75	.075 (1.23)	.150 (2.46)	300075	3000757	3000758	300075X	3000757X	3000758X
100	.100 (1.64)	.200 (3.28)	3000100	30001007	30001008	3000100X	30001007X	30001008X
125	.125 (2.05)	.250 (4.10)	3000125	30001257	30001258	3000125X	30001257X	30001258X
150	.150 (2.46)	.300 (4.92)	3000150	30001507	30001508	3000150X	30001507X	30001508X

TIE RODS

Description	Part Number	Part Number	Part Number
Tie Rod Kit 3 Valves	FT25171A	Tie Rod Kit 7 Valves	FT25171E
Tie Rod Kit 4 Valves	FT25171B	Tie Rod Kit 8 Valves	FT25171F
Tie Rod Kit 5 Valves	FT25171C	Tie Rod Kit 9 Valves	FT25171G
Tie Rod Kit 6 Valves	FT25171D	Tie Rod Kit 10 Valves	FT25171H

Note: Sold individually each assembly requires 4 tie rods & 4 locknuts P.N. U251C

DIMENSIONAL SCHEMATICS

Number of Valves	A	B
3	5-7/16	6-9/16
4	6-3/4	7-7/8
5	8-1/16	9-3/16
6	9-7/16	10-9/16
7	10-3/4	11-7/8
8	12-1/16	13-3/16
9	13-3/8	14-1/2
10	14-11/16	15-13/16

DIVIDER BLOCK COMPONENTS

INLET SECTION

Inlet Type	Part Number
Standard 3/8NPSF	3006

GASKETS

Description	Part Number
Plated steel with bonded Viton® seals	FT25091

END SECTION

Description	Part Number
3000 End Block Section	3007

Notes: See page 12 for cross-port and high pressure indicators.
See page 13 for cycle switch.

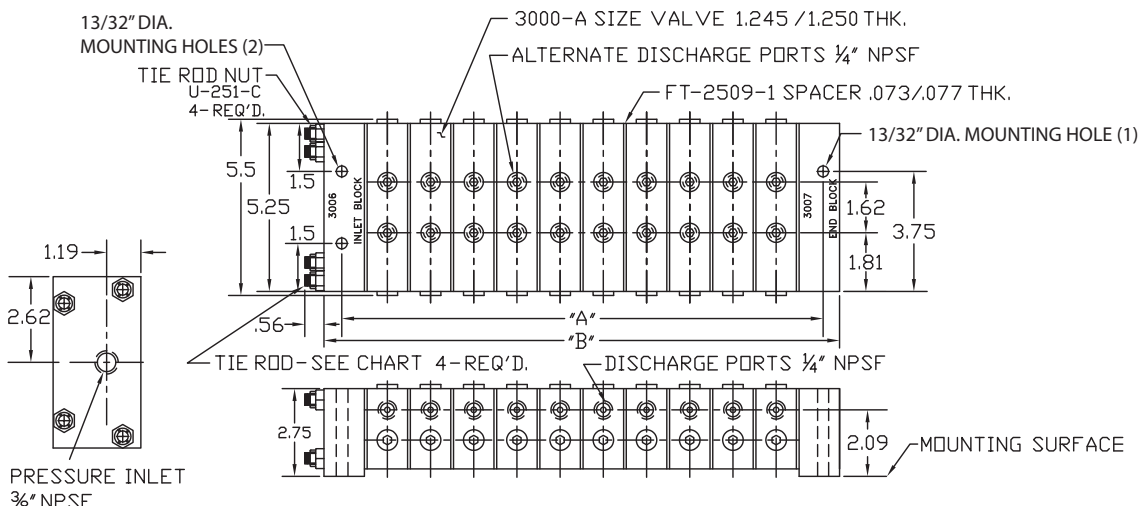

U-Blocks

DESCRIPTION

U-Block divider valves, models UR and UM, are specially designed for use in progressive lubrication systems. Several outlet configurations are available that allow you to tailor the divider valve to your lubrication specifications. Cross-port bars are also available so you can double volume discharge where needed.

OPERATION

Each divider valve has a number of pistons that divide the volume of lubricant equally and forces it out of the valve. When the system is pressurized, pistons are positively displaced in sequence until the cycle is complete, with lubricant being discharged from each outlet. U-Block divider valves will continue to cycle as long as lubricant is being delivered from the pump.

U-BLOCK SPECIFICATIONS

Maximum Operating Pressure	Grease	2175 psi (150 bar)
	Oil	870 psi (60 bar)
Minimum Operating Pressure	203 psi (14 bar)	
Max Operating Frequency (with cycle pin)	60 cycles/min.	
Lubricant	Oil & up to NLGI #2 grease	
Temperature	350°F to 100°F (-10°C to 70°C)	

Refer to the following documents for more info:
+ Datasheet #35426: U-Block Series Divider

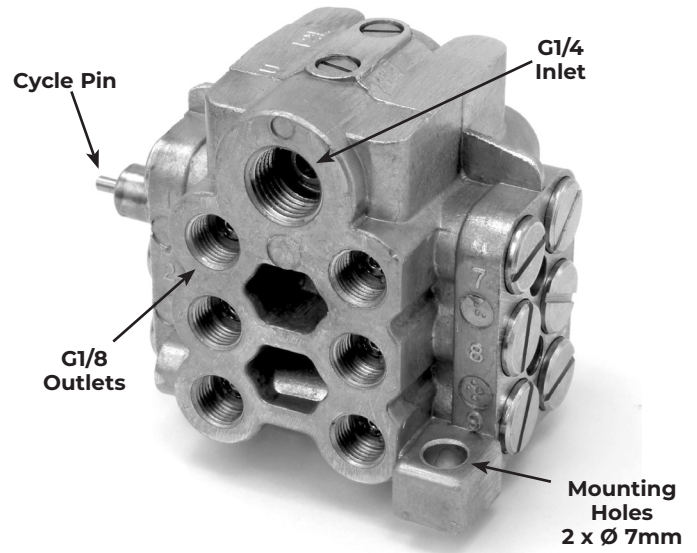

HOW TO ORDER

Number of Lube Outlets	With Cycle Pin	Without Cycle Pin & Switch
4	44159-1	44160-1
6	44229-1	44230-1
8	43659-1	43678-1
10	42879-1	---
12	42999-1	43000-1

ACCESSORIES

Description	Part Number
Cross-port AU-15 Vertical	44602
Cross-port AU-26 Horizontal	44600
Cycle Switch	42902

SureShot Kit

U-BLOCK DIVIDER BLOCK FOR MANUAL LUBRICATION OF MULTIPLE POINTS

For machinery applications with multiple lubrication points, you sometimes need a method to grease them from a centralized location with a manual grease gun.

The SureShot system delivers a positive measured shot of grease to each connected lubrication point through a single manually-fed grease fitting. Just mount the block in a convenient location and route the pre-filled tubing to each lubrication point. Then, walk up to the block and grease your entire machinery!

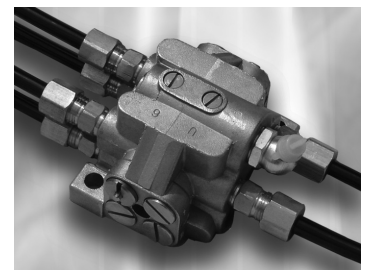

INCLUDED IN A SURESHOT KIT:

- Divider block (4, 6, 8, 10 or 12 outlets)
- Pre-filled tubing
- Hardware for installation (elbow, straight, 45- and 90° degree adapters)

Pre-Filled Tubing	Description	Part #
25'	For 3 or 4 lubrication points	SST4C
50'	For 5 or 6 lubrication points	SST6C
75'	For 7 or 8 lubrication points	SST8C
75'	For 9 or 10 lubrication points	SST10C
100'	For 11 or 12 lubrication points	SST12C



M2500G-3000 Accessories

CROSS-PORT KIT

Cross-port kit is installed in the alternate outlet port of adjacent valves to combine the outputs to feed a single lubrication point.

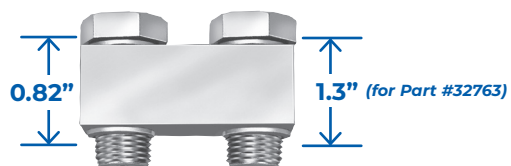

HIGH PRESSURE INDICATORS

These indicators are spring-loaded and can only be reset when system pressure decreases. The indicator's memory pin remains extended until manually reset. They are installed in the alternate outlet port.

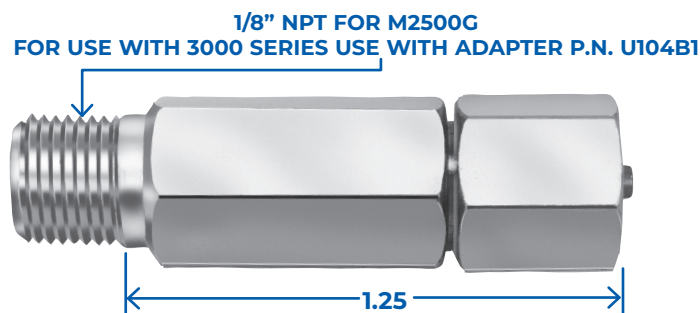

RUPTURE DISC INDICATORS

These indicators burst at a selected pressure to automatically relieve excessive system pressure. They are installed in an alternate outlet port. All indicators are assembled with one rupture disc.

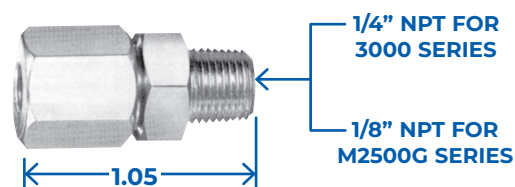

Description	Part Number
M2500G Series	37083G
3000 Series	32763

Description	Pressure Rating	Part Number
Non-Relieving Type for M2500G Series	600 psi	20356
	1200 psi	203512
	1600 psi	203516
	2200 psi	203522
Relieving Type for M2500G Series ¹	1000 psi	213510
	1500 psi	213515
	2000 psi	213520
Non-Relieving Type for 3000 Series ²	600 psi	20356 + U104B1
	1200 psi	203512 + U104B1
	1600 psi	203516 + U104B1
	2200 psi	203522 + U104B1

1: These have small weep hole to relieve pressure.
2: Order high pressure indicator and U104B1 adapter separate.

Description	Burst Pressure	Disc Color	Replacement Disc Kit*	Part Number
For M2500G Series	1450 psi	Yellow	FT15423YWK	10412YW
	1750 psi	Red	FT15423RDK	10412RD
	3250 psi	Purple	FT15423PRK	10412PR
For 3000 Series	900 psi	Black	FT15423BKK	FT25413B
	1450 psi	Yellow	FT15423YWK	-
	1900 psi	Red	FT15423RDK	FT25413RD

* Discs are sold in packs of 10 pieces

M2500G, PVBM & 3000 Cycle Switches

CYCLE INDICATORS/CYCLE SWITCHES

Manifold cycle indicators provide a means of monitoring lube flow thru the system - a pin cycles in and out when lubricant is flowing. Movement of the pin is caused by the piston (the two are pinned together) so that when the piston, and thus the entire manifold, cycles once, the pin moves in and out once. The switches can be wired to warn of system trouble. They can feed electric pulses to a control device such as SS2200 or SC400 controller or customer PLC.

ELECTRICAL CYCLE SWITCHES

M2500G SERIES

Mechanical Cycle Switch

17324 Cycle Switch w/1/2-14 NPSM conduit connector

33583 Bracket (Required with switch)

(Order both parts separate)

Couples to any M2500G metering valve having a cycle indicator pin and provides an electrical signal each time the divider valve operates. SPDT switch is rated 15 amps @ 125/250 VAC, 0.5 amps @ 125 VDC.

MCSA2503 with Automotive Type 3 Pin Connector

Because they use a magnet to sense piston position, entry of contaminants into the system is prevented. These cycle switches may be installed in the end of M2500G valve size 15' and larger. The SPDT switch is rated at 250 VAC/28 VDC-5 Amps.

37786 Visual Cycle Indicator

Visual cycle indicator for monitoring. Reflective orange indicator is visible for over 30 feet. Couples to any M2500G metering valve. Pin reduces output of valve by 0.0038cu.(0.06cc)

PVBM SERIES

66925-1311 & 66925S003 Electrical Prox Cycle Switches

(66925-1311 is PNP/66925S003 is NPN). Provides an electrical signal each time the divider valve operates. N/O contact, operating voltage 10 to 30 VDC, output current 200 mA. (Can also be used with M2500G with special indicator pin valve section).

3000 SERIES

Electrical Cycle Switches

FT15801C8 with 1/2-14 NPSM Conduit Connector

(Also available in Nema 4 switch p.n. LB11398)

Couples to any 3000 metering valve having a cycle indicator pin and provides an electrical signal each time the divider valve operates. SPDT switch is rated 15 amps @ 125/250 VAC, 0.5 amps @ 125 VDC.

17324 & 33583

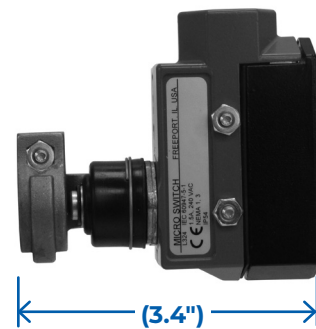

MCSA2503



37786

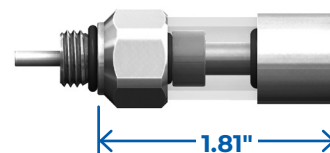

66925S003



Accessories – Cables

ELECTRICAL ACCESSORIES FOR ZONE CONTROL VALVES AND CYCLE SWITCHES

Crouse Hinds/Brad Harrison Automotive-Type Electrical Connectors with Molded Cable

These feature molded 3 pin automotive connectors and are used with cycle switches and type BH Zone Control Valves. The 3-conductor cables are yellow PVC insulated STO rated at 10 amps and 300 volts.

Description	Part Number
6 feet, NEMA 6P, IP68 protection	MCC2505A
12 feet, NEMA 6P, IP68 protection	MCC2505B

M12 4-Pole Electrical Connectors with Cable

These connectors, made to M12 specifications, are used with the PVB Switches and 55105 Lube Point Monitors.

Description	Part Number
Straight, 10 meters long	76928-2863
90°, 10 meters long	76928-2833

Hirschman-Type Electrical Connectors

These connectors, made to DIN 43650 specifications, are used with type HC zone control valves. They include all hardware including gaskets. They are rated at 250 VAC and 16 amperes.

Description	Part Number
For MCZ2501 Series Zone Control Valves. DIN 43650 Form B 11mm blades. 1.12" by 0.82"	MCC2509A
For MCZ2503 Series Zone Control Valves. DIN 43650 Form A. 1.08" square	MCC2510A

Hirschman-Type Electrical Connectors with Cable

These connectors, made to DIN 43650 specifications, are used with type HC zone control valves. They include all hardware including gaskets. They are rated at 250 VAC and 16 amperes.

Description	Part Number
For MCZ2503 Series Zone Control Valves. DIN 43650 Form A. 1.08" square 15'FT long	35732-1



MCC2505



76928-2863
76928-2833



MCC2509A



MCC2510A



35732-1

Remote Zone Valves

HOW TO ORDER GREASE VALVES

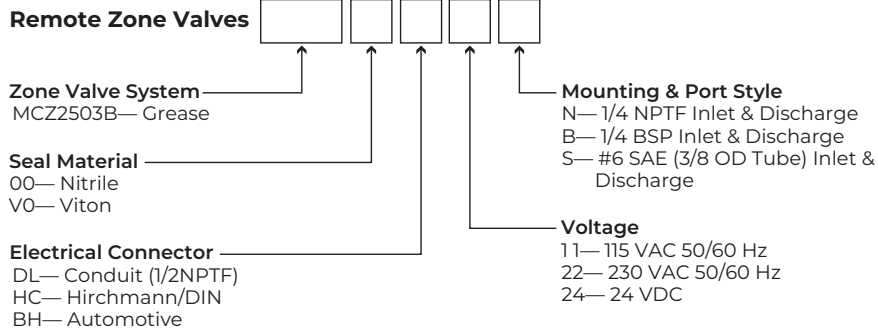

**Remote-Grease
MCZ2503B**

Note: All Zone Control Valves are sent standard as normally closed.
Contact factory if normally open is required.

EXAMPLES

- For a remote zone control in a grease system, nitrile seals, a Hirschmann connector, 24 volt DC current, and with NPTF ports, order **MCZ2503B00HC24N**.

HOW TO ORDER OIL VALVES

	PART NUMBER	VOLTAGE	SEALS	ELEC CONN
OIL VALVES*	38152M115	24VDC	VITON	Hirschmann/DIN
	38152M116	115VAC	VITON	Hirschmann/DIN
	38152M117	230VAC	VITON	Hirschmann/DIN

BODY*	PART NUMBER	DESCRIPTION
	85467	Remote zone valve body, SAE 8 Ports



REMOTE ZONE CONTROL VALVES

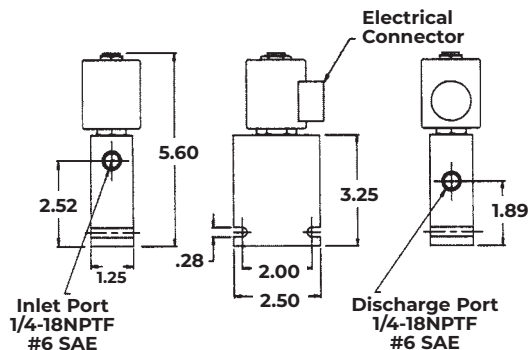

Grease Service (MCZ2503 Series)

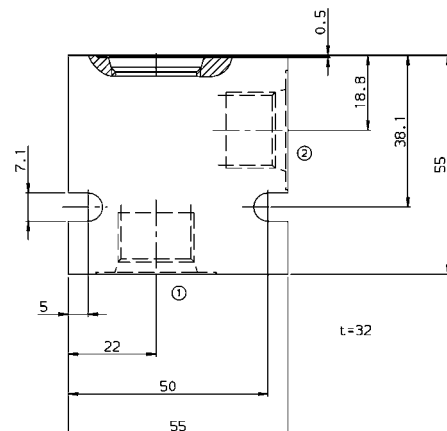

Oil Service (85467 Body Dimensions)

Multi Purpose Zone Valves

The Solenoid Valve is electrically-operated and is used to open or close lubrication lines for zone systems, alternating system pumps and other applications where a user needs automatic operation.

A sub-plate with mounting bolts is included. Configuration can be customized by the customer. Options include zone valve normally open or normally closed & diverter valve.

PLC or remote operation is required.

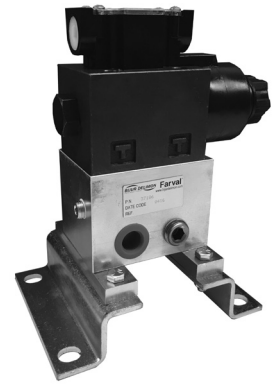

TECHNICAL DATA

	37186	37186-1	37186-2
Applied Voltage	120 VAC /	240 VAC	24 VDC
Frequency	60 Hz	60 Hz	---
Holding Current	0.49 amp	0.24 amp	1.5 amp
Holding Power	34 W	33 W	36 W
Voltage Range	80-130 V	180-250 V	21.6-26.4 V
Max. Operating Pressure	5000 psi (345 bar)		
Operating Temperature	41°F to 140°F (5°C to 60°C)		
Lubricants	Oil, Grease up to NLGI #2		
Maximum Flow	Up to 12 gpm		
Ports (Inlet/Outlet/Relief)	1/2" NPTF		
Weight	7.9 lb (3.6 kg)		

HOW TO ORDER

Name	Description	Part #
Solenoid Valve Complete assembly	115 VAC single coil, zoning valve and sub-plate	37186
	230 VAC single coil, zoning valve and sub-plate	37186-1
	24 VDC single coil, zoning valve and sub-plate	37186-2

DIMENSIONAL SCHEMATICS

Measurements shown in inches.

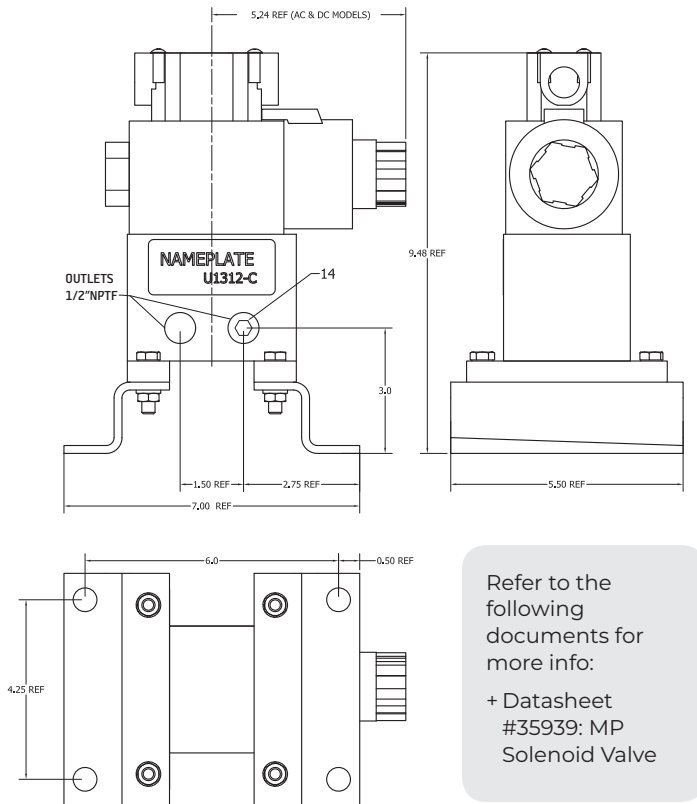

CONFIGURATION OPTIONS

WHEN USED AS A ZONE CONTROL VALVE
NORMALLY CLOSED POSITION

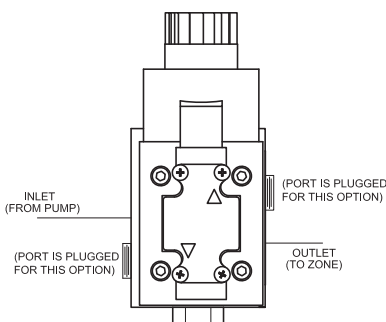

WHEN USED AS A ZONE CONTROL VALVE
NORMALLY OPEN POSITION

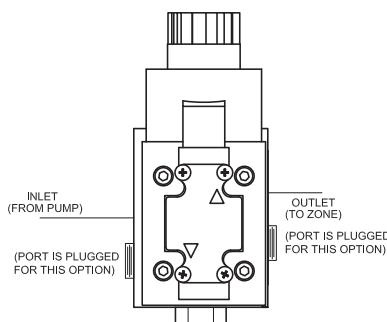

WHEN USED AS A DIVERTER VALVE

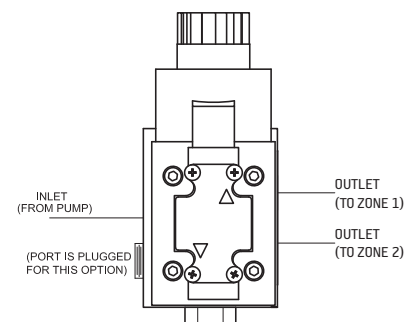

GPO Motor Driven Oil Gear Pump

The GPO Lubricator is a motor-driven gear pump that is designed for use with single line centralized lubricating systems utilizing progressive distributors. Standard features include: liquid level indicator, pressure gauge and strainer filler cap. An adjustable pressure regulating oil bypass valve is standard on Progressive systems. Programmable controllers are available to operate the lubricator.

TECHNICAL DATA

Maximum Discharge Pressure	1000 psi (69 bar)
Operating Temperature Range	40°F to 105°F (5°C to 40°C)
Reservoir Capacities	6 liter, 12 liter, 30 liter
Discharge	275cc/min (Single Phase) 500cc/min (Three Phase)
Output Connection	1/4" NPT (left and right options)
Oil Viscosity	20-1500 cSt



Refer to the following documents for more info:
+ Datasheet #35641: GPO Lubricator

HOW TO ORDER

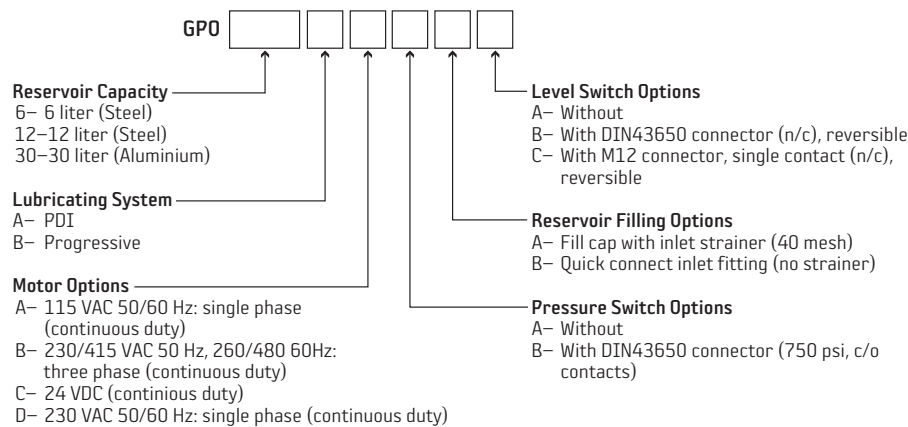

DIMENSIONS

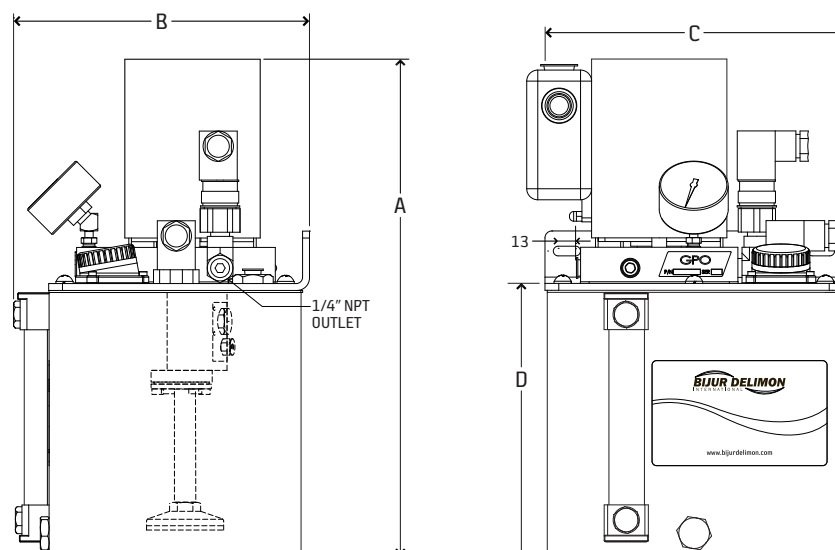

DIM	6 liter	12 liter	30 liter
A	360mm	318mm	468mm
B	215mm	260mm	340mm
C	229mm	370mm	490mm
D	200mm	156mm	291mm

Dynamis Maxx

Dynamis Maxx Lubricators are electrically driven piston pumps designed for use with series progressive systems. These lubricators can be fitted with up to three independent piston elements providing positive displacement output to series progressive divider valves. Dynamis Maxx Lubricators are available with an integral pCo programmable controller, low level switch and various reservoir capacities. Operating voltages are 12 or 24 VDC.

TECHNICAL DATA

Reservoir Capacity	4 and 8 liter (8 and 16 lb.)
Grease	NLGI grade 000-2
Relief Valve Setting	2320 psi (160 bar) ¹ & 4350 psi (300 bar)
Discharge/min.	2.9cc (0.18 cu. in.) Per element/outlet
Operating Voltage	12 or 24 VDC
Outlet Connection	8MM Tube fitting (or G1/4 port)
Electrical Connections	DIN 43650, 3 pole for power supply Units with internal control have M12x1, 8 pole for status & M12X1, 4-pole for cycle switch. Units without internal control have M12X1 4-pole for level switch connection.

¹: Higher pressure settings may be available. Contact Bijur Delimon for details.



Dynamis Maxx
Progressive Lubricator

HOW TO ORDER

Name	Voltage	Reservoir Capacity	Options	Relief Valve	Part Number
Dynamis Maxx Progressive Lubricator	12 VDC	4 liter (8 lb.)	Low level switch & controller	160	37555
			Low level switch	160	37551
	24 VDC	4 liter (8 lb.)	Low level switch & controller	160	37553
			Low level switch & controller	300	37957
		8 liter (16 lb.)	Low level switch	160	37552
			Low level switch & controller	160	37554
			Low level switch & controller	300	37729

Refer to the following documents for more info:
+ Datasheet #35687: Dynamis Maxx Lubricator

MultiPort II Pumps

The MultiPort II Lubricator is an electrically driven multiple outlet lubrication unit designed primarily for use with progressive divider valve systems. The unit is capable of housing up to three independent or combined pumping elements for direct feed to lubrication points or through a distribution network of progressive divider valves. These lubricators are available with 12 & 24 VDC motors which make them ideal for use in mobile applications. An integral controller is available, or the pump can be controlled by an external controller (such as SMDC) or by the customer's PLC/DCS/etc.



SPECIFICATIONS

Operating Temp. Range¹	24VDC	-4 ° F to 122 ° F (-20 ° C to 50 ° C)
	12VDC	14 ° F to 122 ° F (-10 ° C to 50 ° C)
Pumping Elements	1 - 3	
Output per Minute	3.0 cc (0.18 cu. in.) per element	
Max. Working Pressure	3600 psi Grease	
Motor²	2 amp (24VDC)	4 amp (12VDC)
Enclosure Rating	IP66	
Grease	NLGI grade 000-2	
Discharge Port	1/4" NPTF or 1/4" BSPP	
Grease Fill Connection	Quick disconnect 7241-1B or Zerk	

- 1: Lubricant must be pumpable at the operating temperature. Contact lubricant manufacturer with specific questions.
 2: Operates at 40 rpm @ 68 ° F, 1000 psi back pressure

DIMENSIONS

'L' DIMENSIONS

Description		"L"
With Low Level Switch	3 Liter (7 lb.)	455
	7 Liter (15 lb.)	655
Without Low Level Switch	3 Liter (7 lb.)	419
	7 Liter (15 lb.)	619

Refer to the following documents for more info:
 + Datasheet #36980: Multiport II Lubricator -Progressive

HOW TO ORDER

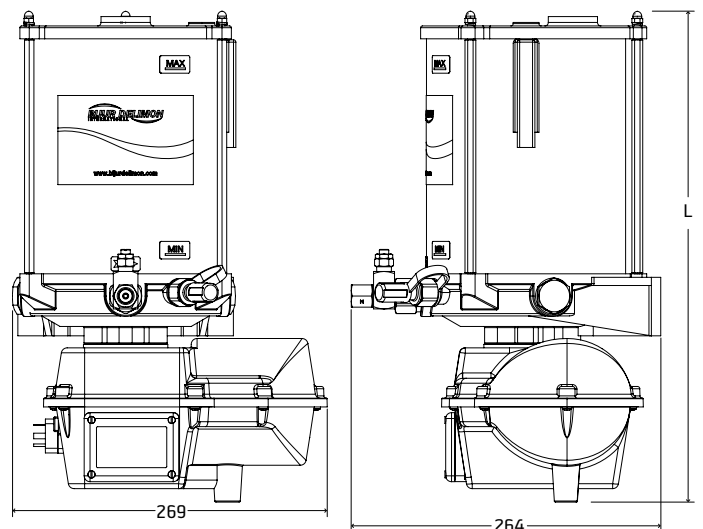
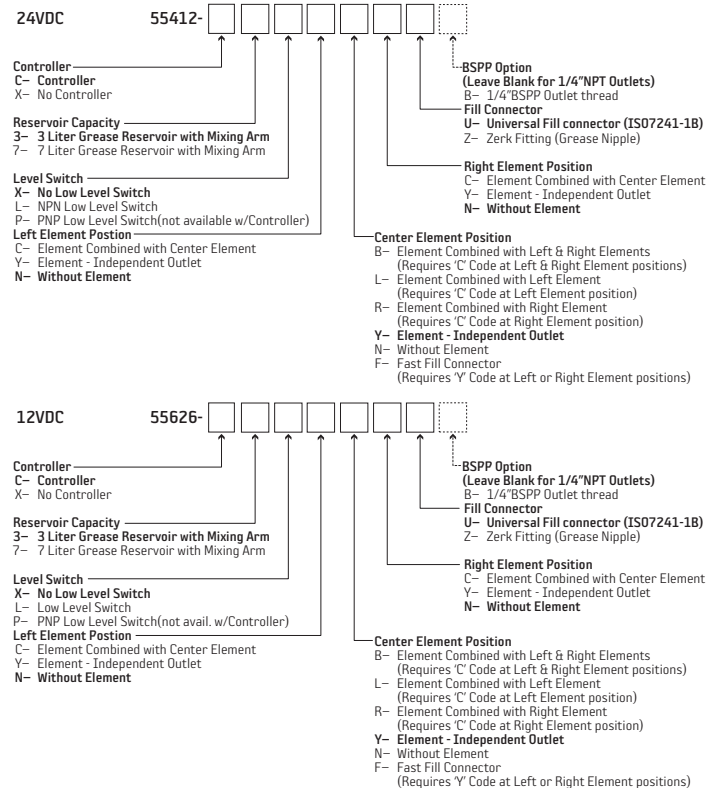

MultiPort Pumps

Rugged, compact, electric, motor-driven pump, equipped with fixed output pumping elements to discharge grease and oil over a wide operating range. Low level switches are available on some models. Available in 110 VAC & 220VAC 1PH and 220/380 VAC 3 PH.

Up to three independent feed lines can be used with the MultiPort pump. The pump can be used with all single line progressive lubricating systems.

A selection of controller/monitors are available to operate single phase MultiPort Pumps (SS2200, SMAC. See pages 28, 29).



SPECIFICATIONS (ALL MODELS)

Operating Temp. Range	0°F to 120°F (-18°C to 49°C)
Pumping Elements	1 installed (can add 1 or 2 more)
Output per 1 rpm¹	0.16cc (0.01 cu. in.)
Max. Working Pressure	3600 psi Grease, 2900 psi Oil
Oil Maximum	5000 SUS
Grease Maximum	NLGI # 2
Discharge Port	1/4" NPTF 1/4" BSPP (230vac 1PH only)
Grease Fill Connection	Male filler fitting (quick disconnect)

¹: Operates at 32 rpm (60 Hz) @ 68 °F, 1000 psi back pressure

ELECTOR MOTOR SPECIFICATIONS

Voltage	H.P. Rating	Full Load Amps	Protection
110VAC 1PH	.08	1.83	IP55
220VAC 1PH	.08	0.68	IP55
220/380VAC ² 3PH	.08	0.68	IP55

²: Can be used up to 440VAC for intermittent use only.

DIMENSIONS

Reservoir	A	B	C
2 liter (4 lb)	420	370	245
4 liter (8 lb)	520	470	345
8 liter (16 lb)	720	670	545
2 liter (4 lb) Rubber Lid	N/A	330	205

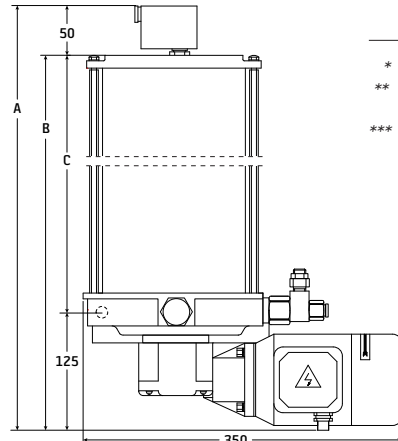

HOW TO ORDER

GREASE				
Voltage	Reservoir Capacity	Reservoir Material	Low Level Switch	Part #
110 VAC	2 liter (4 lb)	Plastic	No	28569-1NF***
			Yes	41320-1NF
	4 liter (8 lb)	Plastic	Yes	31801-1NF
220 VAC**	8 liter (16lb)	Plastic	Yes	59827-1NF
			Yes	MULTI2BD
	4 liter (8 lb)	Plastic	Yes	MULTI4BD
220/380/440* VAC Three Phase	8 liter (16lb)	Plastic	Yes	MULTI8BD
			No	28570-1NF***
	2 liter (4 lb)	Plastic	Yes	30558-1NF
			No	28576-1NF
			Yes	30559-1NF
8 liter (16 lb)	Metal	Yes	28730-1NF	

OIL				
Voltage	Reservoir Capacity	Reservoir Material	Low Level Switch	Part #
110 VAC	2 liter	Plastic	Yes	41320-1INFO
	4 liter	Plastic	Yes	31801-1INFO
220/380/440* VAC Three Phase	4 liter	Plastic	Yes	30559-1INFO
	8 liter	Metal	Yes	28730-1INFO

* Can be used up to 440VAC for intermittent use only.

** Note: MULTI2BD, MULTI4BD & MULTI8BD are 1/4" BSPP outlet, all others are 1/4" NPTF.

*** These models have a rubber lid.

Refer to the following documents for more info:
+ Datasheet #35693: Multiport Lubricator

CLP Cartridge Lube Pump

GENERAL

The Cartridge Lube Pump is an electrically driven, single outlet, pump designed for use with the universal grease cartridges widely available in industry today. The lubricator is available with 12 or 24 VDC or 115/230 VAC power making them ideal for use in a range of industrial and mobile applications. An integrated controller enables seamless operation and external communication to host machine. The Cartridge Lube Pump can be ordered standalone or with a PVB kit installed and configured for 6mm O.D. Nylon Tubing secondary lines. This pump was developed to meet a growing demand for replacing bulk grease lubricators with a system that could handle the more convenient cartridge greases.



SPECIFICATIONS

Cartridge Type	Option A	Type A - 400g Universal Cartridge (14 ounce cartridge)
	Option B	Type B - 400g Threaded Cartridge
	Option C	Type C - 500g Threaded Cartridge
Lubricant	Up to NLGI #2	
Max working Pressure	120 bar (1740 psi)	
Flow Rate	8cc/min	
Outlet Port	G1/4 (right hand side of pump, 1 alternate outlet bottom of pump)	
Operating temperature	-20°C to +50°C (-4°F to 122°F)	
Operating Voltage	12 VDC / 24 VDC / 115-230 VAC	
Degree of Protection	IP67	
Electrical Controls	Option G	On Board Controller
	Option F	Terminal Strip
Approvals	CE	

DIMENSIONS

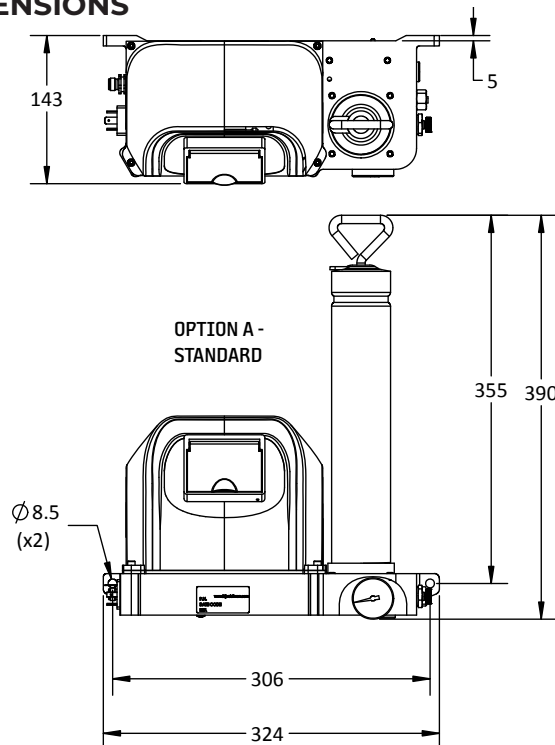

HOW TO ORDER

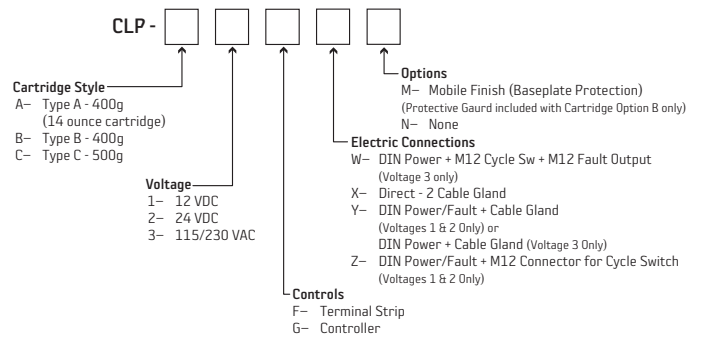

HOW TO ORDER WITH PVB KIT

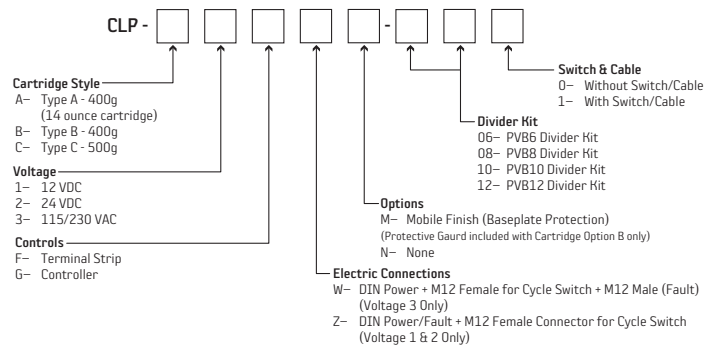

Notes:
PVB Kits include 3 meters of 6mm secondary line and one 1/8NPT straight lube point fitting per outlet.

Refer to the following documents for more info:
+ Datasheet #36916: CLP Lubricator

CS2000 Central Stations

GENERAL

CS2000 stations store, control, and supply the lubricant to systems. Depending on reservoir size, they can be used in systems that service anything from small machine tools to large machinery in steel mills, or large off road machinery such as power shovels, and drag lines. Standard items on these stations include a switch arrangement for automatic level warning systems, visual level indication, an adjustable relief valve and an electrically driven pump. A variety of reservoir types and sizes and a high level warning switch are offered. Kits are also available for mounting controls and NEMA 4 applications.

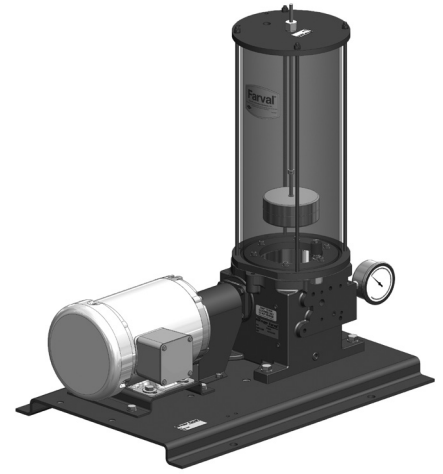

SPECIFICATIONS

Operating Temp. Range	0°F to 120°F (-18°C to 49°C)
Pump Type	Dual Piston
Pump Output	6.0 in ³ /min @ 175 strokes/min @ 1000 psi (70 bar)
Max. Working Pressure	3500 psi (240 bar)
Relief Pressure	3000 psi (207 bar)
Motor Voltages*	115/230 VAC Single Phase 230/460 VAC 3 Phase 230/380 VAC 3 Phase 440/480 VAC 3 Phase 575 VAC 3 Phase
Low Level Switch	Yes
High Level Switch	Optional
Reservoir	Oil & Grease
Oil/Grease	Oil and Grease up to NLGI #2
Discharge Port	1/4" NPTF
* Other voltages and configurations available upon request. Contact BDI Engineering.	

HOW TO ORDER

GREASE					
Voltage	Reservoir Capacity	Reservoir Material	Level Switches		Part Number
			Low	High	
115/230 VAC Single Phase	12 Liter (24 LB)	Steel	X	X	CS2126
	50 Liter (100 LB)	Steel	X	X	55182*
230/460 VAC 3 Phase	12 Liter (24 LB)	Steel	X	-	CS2124
	50 Liter (100 LB)	Steel	X	X	CS21101
230/380 VAC 3 Phase	12 Liter (24 LB)	Steel	X	-	CS2134
	12 Liter (24 LB)	Steel	X	X	CS21341
	50 Liter (100 LB)	Steel	X	X	55117*

Dimensions Reference

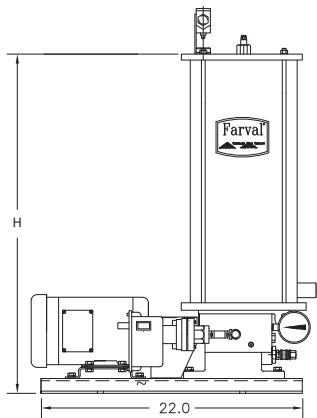

Reservoir	H
12 Liter (24 LB)	29"
50 Liter (100 LB)	50"-69"
24 Liter (6 Gal)	29"

OIL					
Voltage	Reservoir Capacity	Reservoir Material	Level Switches		Part Number
			Low	High	
115/230 VAC Single Phase	24 Liter (6 Gal)	Steel	X	-	CS2105
	24 Liter (6 Gal)	Steel	-	-	CS2106
230/460 VAC 3 Phase	24 Liter (6 Gal)	Steel	X	X	CS2107

* Special Option Includes SC400 Controller

-Contact BDI Engineering for more information on specials.

Refer to the following documents for more info:
+ Manual #2011F: CS2000 Stations

Electric Barrel Pump

Bijur Delimon's AC or DC Electric Barrel Pumps will replace the air or hydraulic operated pumps now used for lubrication systems on mobile or stationary equipment. Installation is cleaner - no air or hydraulic lines to install/leak. Simply wire into the machines power supply. Pressure rated to 300 bar (4350 psi). Will fit original refinery 120 and 400 lb drums (50kg & 185kg). Optional drum covers and follower plates are available. (Bung Adapter F360002 is included with pumps.)

OPERATION

The pump end (bottom) consists of a hardened steel bushing, through which the piston runs. As the piston strokes down, grease is pushed past the check valve ball and out through the extruded discharge holes in the pump stem. As the piston strokes up, the check valve prevents drawback, and a vacuum is created inside the bushing. When the piston uncovers the suction holes in the bushing, another charge of grease is drawn in through the suction ports on the bottom of the stem and into the bushing. The cycle then repeats.

SPECIFICATIONS

Standard Tube Lengths/Fits Drum Size¹	120 lb. (50 kg), 400 lb. (185 kg)
Voltages	24 VDC 115/230 VAC (50/60 Hz) Single Phase
Amp Draw	24VDC² 15 Amp draw @ 3500psi 20°C (68°F) with NLGI #2
	115VAC³ 4 Amp draw @ 3500psi 20°C (68°F) with NLGI #2
	220VAC⁴ 2 Amp draw @ 3500psi 20°C (68°F) with NLGI #2
Lubrication Flow⁵	150cc/minute @ 140 bar, +20°C (9 cu.in. @ 2030 psi, +68°F)
Pump Pressure	300 bar max/240 bar recommended (4350psi / 3480 psi)
Systems⁶	Progressive Pressure Relief Valve Included
	Injector Vent Valve & Pressure Relief Valve Included
Relief Valve Pressure	240 bar / 3500 psi
Vent Valve Voltages	24 VDC 115/230 VAC (50/60 Hz) Single Phase
Operating Temperature⁷	-25°C to +60°C (-13°F to +140°F)
Pressure Gauge	350 bar Included (5000 psi)
Lube Outlet Port	1/2" NPSF (F)
Lubricants⁸	NLGI #000 to #2
Rating	IP66
Noise Level⁹	75dB



120 lb. Electric Barrel Pump



400 lb. Electric Barrel Pump

- 1: Bung Bushing F360002 is included with pumps.
- 2: 6 Amp draw spike. Recommend 40A fuse max.
- 3: 5 Amp draw spike. Recommend 7A fuse max.
- 4: 2.5 Amp draw spike. Recommend 4A fuse max.
- 5: Flow rate is for 60 Hz motors. 60 Hz motor can operate on 50 Hz but pump flow is reduced.

- 6: Suitable for Dualine system when paired with a hydraulic or electric reversing valve.
- 7: Lower temperatures may be possible with suitable grease and/or heated reservoir/piping.
- 8: EBP will also work pumping oils.
- 9: Noise level measured at 3' (1 m) from the pump.

HOW TO ORDER

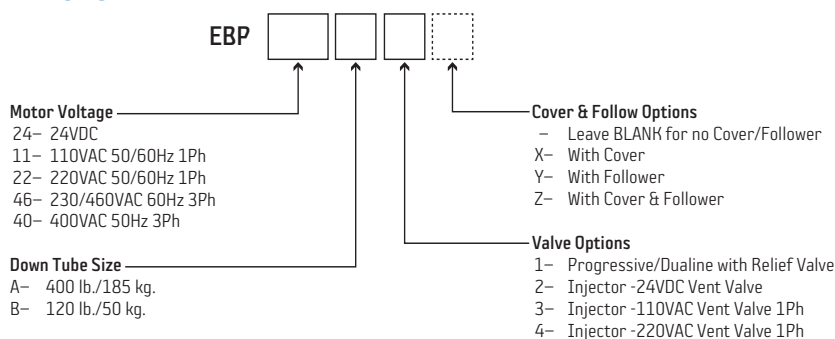

Refer to the following documents for more info:
+ Datasheet #36922:
Electric Barrel Pump

TP11, 12, 13, 22, 23 Pumps

The pumps meet a wide range of requirements as shown in the table below. The discharge capacities range from 0.015 to 0.170 cubic inches per stroke. These pumps offer a range of pressure ratios, and are available as single acting, spring return or double acting, power return.

APPLICATION

TP Pumps are used on central pumping stations with T30 or T32 reservoirs; or in bulk oil installations without reservoirs. They are actuated by air or hydraulic power.

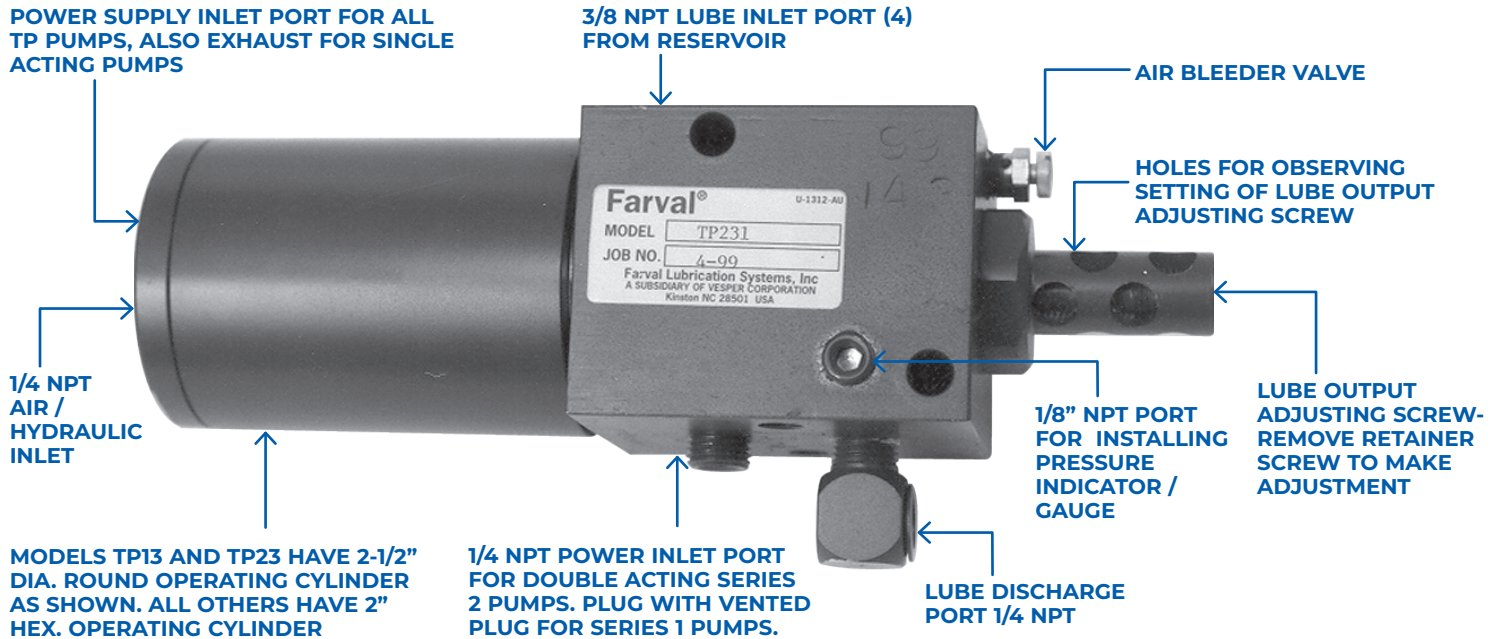

PUMP SPECIFICATIONS

Order Code LTR.	Pump Part #	Discharge Cu. In Per Stroke (C.C.)		Type ¹	Method of Pump Piston Return	Pump Pressure Ratio ²	Air or Hydraulic Input Pressure ³		Maximum Cycles Per Min.			
		Minimum	Maximum				Minimum	Maximum	At Max. Disch. Adjustment		At 50% Max. Disch. Adjustment	
									NLGI #1	NLGI #2	NLGI #1	NLGI #2
C	TP121C	.015 (.25)	.068 (1.1)	Air	Spring	18:1	60 psi	200 psi	40	20	50	25
E	TP131C	.015 (.25)	.068 (1.1)	Air	Spring	50:1	30 psi	50 psi				
J	TP222C	.035 (.57)	.170 (2.8)	Hydraulic	Hydraulic	7:1	200 psi	500 psi				
K	TP231C	.035 (.57)	.170 (2.8)	Air	Spring	18:1	60 psi	200 psi				

1: Listings in this column show our recommendations based on pump pressure ratios in relation to typical machine air and hydraulic power supply pressures. Hydraulic pressure must fall below 2 psi during relief cycle when using pumps for single acting (spring return) hydraulic service.
 2: Pressure ratios decrease at lower operating pressures - will increase slightly (up to 10%) at higher operating pressures.
 3: When using pump input pressures that generate pump output pressures over 3000 psi use either rupture disc indicator (Part No. 10412PR) in the pump port to prevent hazardous over pressurizing of lube system.
 4: Maximum lube inlet pressure is 15 psi.

Refer to the following documents for more info:
 + Datasheet #35609: TP Lubricator

T30 and T32 Reservoirs

Typical oil and grease reservoirs are shown below and characteristics of the reservoirs are tabulated in the table. The low-level switch is single pole double throw with a UL rating shown below.

APPLICATION

These reservoirs are used with the pumps described on page 15. When lubricating typical machine tools, they require 200 hours of system operation before refilling.

Model	Description
T30 and T32	10 amps at 125/250, or 3 amps at 480 volts A.C.
	0.5 amps at 125 volts D.C.
	0.25 amps at 250 volts D.C.

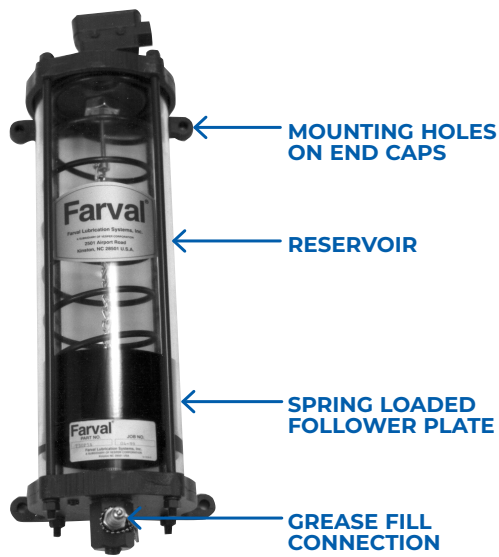

**Grease Reservoir T30P5AC
(Shown without pump attached)**



Reservoir - Shown with pump attached

MODELS T30 AND T32

Body Material	Reference Letter	Lubricant	Capacity	Lubricant Level Indication	Part Number
Steel	B	Grease	5 pounds	Level Switch, Stem	T30S5AC
Plastic	F	Grease	5 pounds	Level Switch, Transparent	T30P5AC
	G	Oil	2.5 quarts	Transparent	T30P4BC
	R	Grease	10 pounds	Level Switch, Transparent	T32P5AC
	S	Oil	6 quarts	Transparent	T32P4BC

TS30 Pumping Stations

Complete pumping stations consist of various combinations of the reservoirs, pumps, etc., listed in the ordering code tables on this page.

APPLICATION

These stations lubricate machines having pneumatic or hydraulic power. All models use TP pumps and supply grease or oil.

DIMENSIONAL SCHEMATICS

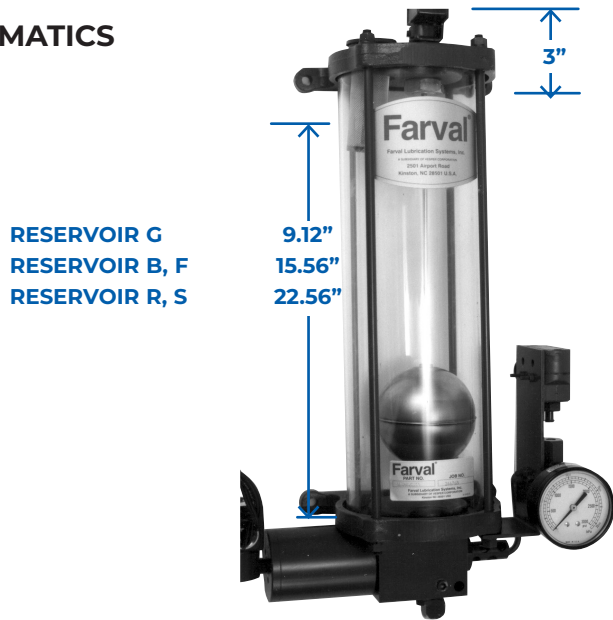

RESERVOIR G
RESERVOIR B, F
RESERVOIR R, S

TS30-TKEXA Station with Pump,
Reservoir and Accessories

HOW TO ORDER

TYPICAL ORDERING CODE: TS30 STATIONS (PART #: TS30SKEXA)

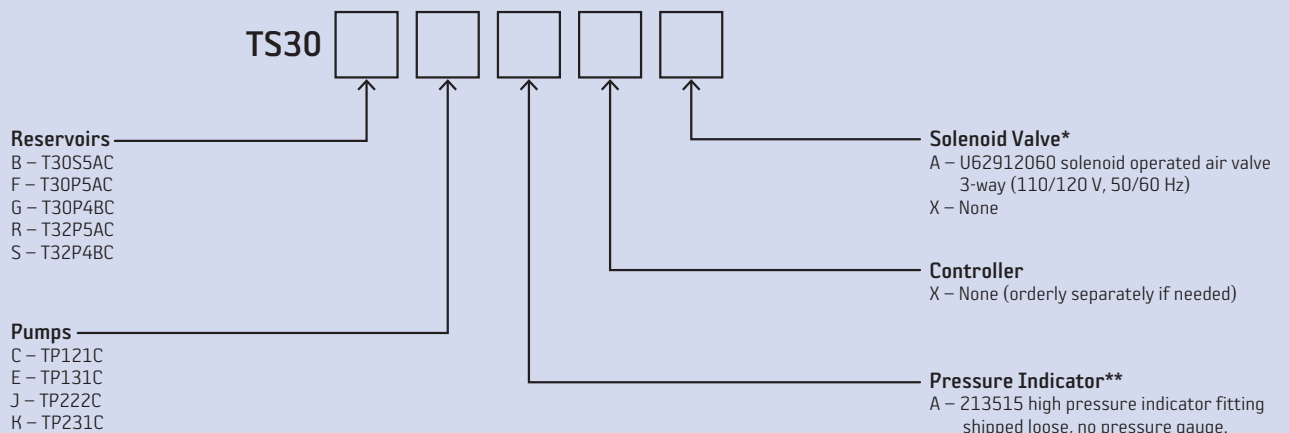

* These solenoid valves are normally used with single acting spring return pumps only (-1 Series).
** T3010431Y has been replaced by 85287.(04/2020)
Replacement Rupture Disk Kit P.N. FT1557 will continue to still be available to order for previous style T3010431Y. See Tech-Sheet TS019 for details.

SureMatic Air-Operated (Single Stroke) Grease and Oil Pumps



The SureMatic Lubricator comprises a piston discharge pump actuated by air, controlled by an electric solenoid 3-way valve. Models are available to handle grease and oil. Low level switch is standard on all models.

APPLICATION

Unit discharges lubricant on single action air powered forward stroke and actuates all divider valves connected to the single line centralized distribution network.

Refer to the following documents for more info:
+ Datasheet #35485: SureMatic Lubricator

TECHNICAL DATA

Lubricator Reservoir Capacity	Oil 2.0, 3.5 and 5.0 liter / Grease 4, 7, and 10 pound
Discharge Range	1.0-8.0cc (adjustable) / .060-.480 cubic inch
Pressure Ratio/Lubricant Discharge/Inlet Air	18:1
Max/Min Permissible Inlet Air Pressure	150/40 psi
Maximum Stroke Rate (full stroke, 8cc)	Approximately 8 strokes/min.
Maximum Ambient Temperature Range	0-180°F
Materials	Aluminum pump; Buna N seals; acrylic reservoir

SPECIFICATION FOR OIL PUMPS (150-8000 SSU)

Reservoir Capacity Liters	Air Inlet	Lube Outlet	Lubricant Oper. Press. Max.	Dimensions H x W x L (MM)	Part Number
4 Pints (2 LT)	1/4" NPTF (F)	1/4" NPTF (F)	2700 PSI (186 bar) ¹	14" x 6-3/8 x 10" (356 x 162 x 254)	18137C
7 Pints (3.5 LT)				18" x 6-3/8 x 10" (457 x 162 x 254)	18138C
10 Pints (5 LT)				23" x 6-3/8 x 10" (584 x 162 x 254)	18139C

1: Max Lube Pressure @ 150 psi air pressure (10 bar).
2: For timers, see page 29.

SPECIFICATIONS FOR GREASE PUMPS (UP TO NLGI #2)

Reservoir Capacity Liters	Air Inlet	Lube Outlet	Lubricant Oper. Press. Max.	Dimensions H x W x L (MM)	Part Number
4 LB (2 KG)	1/4" NPTF (F)	1/4" NPTF (F)	2700 PSI (186 bar) ¹	14" x 6-3/8 x 10" (356 x 162 x 254)	18130-2.0C
7 LB (3.2 KG)				18" x 6-3/8 x 10" (457 x 162 x 254)	18130-3.5C
10 LB (4.6 KG)				23" x 6-3/8 x 10" (584 x 162 x 254)	18132C

1: Max Lube Pressure @ 150 psi air pressure (10 bar).
2: For timers, see page 29.

Air Grease Drum Pumps

55:1 PM3 STD DUTY AIR OPERATED GREASE DRUM PUMPS

High pressure grease pumps handle all types of grease up to and including NLGI #2 directly from 35 lb., 120 lb. and 400 lb. grease containers. Highly efficient double-action pump design assures even flow of fluid, low noise level and low air consumption. Built in exhaust mufflers, standard.



Model F306 Model F308

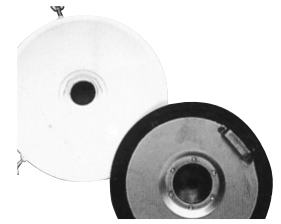

Steel Follower Plates

F306 (For 120 lb. Open Top Drum)	Part #
Includes: 55:1 Ratio pump with cover mounting adapter	F302
Deluxe drum cover for 120 lb. drum	F1936
Connecting hose installation hook-up kit	F903 ¹
F308 (For 400 lb. Open Top Drum)	Part #
Includes: 55:1 Ratio pump with cover mounting adapter	F304
Deluxe drum cover for 400 lb. drum	F1938
Connecting hose installation hook-up kit	F903 ¹
F335 (For 35 lb. Pail)	Part #
Includes: 55:1 Ratio pump with cover mounting adapter	F300
Deluxe cover for 35 lb. pail	F1934
Connecting hose installation hook-up kit	F903

1: F903 consists of 2' Air hose, 5' Grease hose, 1/4" Quick disconnect, and high pressure swivel coupler.

2: Order Follower Plate separately

80:1 PM60 HEAVY DUTY AIR OPERATED GREASE DRUM PUMPS

Very high pressure and high volume delivery double acting pump for use in applications that require extra pressure and volume output and where cold temperatures or low air pressure could limit pump performance. Pumps can be used with grease up to NLGI-2 viscosity. These pumps can be used in large distribution systems that include simultaneous operation outlets.

F534820 (For 120 lb. Open Top Drum)	Part #
Includes: 80:1 Ratio HD pump with cover mounting adapter	F532821
Heavy Duty drum cover for 120 lb. drum	F418017
Heavy Duty Follower Plate for 120 lb. drum	F417011
Connecting hose installation hook-up kit	F534103 ¹
F534810 (For 400 lb. Open Top Drum)	Part #
Includes: 80:1 Ratio HD pump with cover mounting adapter	F532811
Heavy Duty drum cover for 400 lb. drum	F418026
Heavy Duty Follower Plate for 400 lb. drum	F417009
Connecting hose installation hook-up kit	F534103 ¹

1: F534103 consists of 5' Air hose, 5' Grease hose, 1/2" Quick disconnect, and high pressure swivel coupler.

DRUM HEATED INSULATED BLANKETS

Description	Part Number
Fits 120 lb. Drum (15 gal/57 liter)	37506
Fits 400 lb. Drum (55 gal/208 liter)	55286

PM3 TECHNICAL DATA

Max. Air Pressure	140 psi (10 BAR)
Min. Air Pressure	40 psi (3 BAR)
Avg. Air Consumption	5 cu. ft./min. (150L/min.)
Max. Delivery	21 cu. in./min. or 0.7lb/min (344 cc/min.)

PM3 STEEL FOLLOWER PLATES: RUBBER GROMMET AND WIPER

Description	Part Number
Follower for 35 lb. pail	F962
Follower for 120 lb. drum	F964
Follower for 400 lb. drum	F966

PM60 TECHNICAL DATA

Max. Air Pressure	100 psi (7 BAR)
Min. Air Pressure	20 psi (1.5 BAR)
Avg. Air Consumption	35 scfm (1000NI/min.)
Max. Delivery	165 cu. in./min. or 5.5lb/min (2703 cc/min.)



LOW LEVEL SWITCH KITS FOR PM3 & PM60

Description	Part Number
120 lb. drum	LC10243
400 lb. drum	LC11036

1: Requires cover and follower plate - order separately.

2: Customer/user to provide 15/16" hole in cover.

3: Can be used with any style pump.

Refer to the following documents for more info:
 + Catalog #33136: Industrial Lubrication Pumps
 + Datasheet #35745: Drum Heater Blankets

Manual & Miscellaneous Pumps

MANUAL PUMPING STATIONS

For bearings that require an application of lubricant infrequently, the manually-operated pumping unit is used, and may be located on the machine or at any convenient point nearby.

These units consist of a double-acting piston pump, reciprocated by a hand lever through a rack-and-gear segment. A quick-fill connection provides a convenient means of filling the reservoir, and an inlet filter screen gives added protection against the entry of dirt.

Where oil is employed, a float with oil level rod replaces the grease follower plate. Three sizes of reservoirs provide a supply of lubricant adequate for the number of bearings being lubricated.

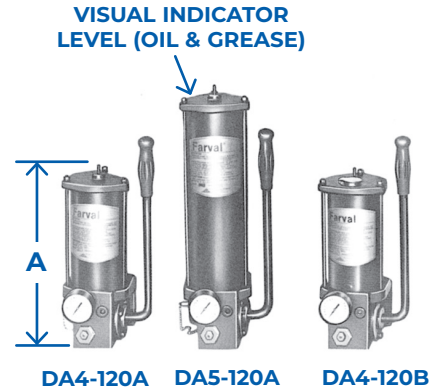

Note: Series 120 pump is designed for single line lubricating systems and series 102 for jacking heavy loads.

Refer to the following documents for more info:
+ Datasheet #35518: DA Lubricator

Discharge Per Cycle*	Lube Type	A (Max.)	Reservoir Capacity	Part Number
0.45 cu. in. (7.44 cc)	Grease	24	4-1/2 lb	DA4120AC
		37	8-1/4 lb	DA5120AC
	Oil	22	2-1/2 qts	DA4120BC
		49	6-1/2 qts	DA6102BC

1: This is the volume discharged by one in and out operation of the hand lever.

Lube Point Monitor



The 55105 Lube Point Monitor is an accurate oval gear mechanism that incorporates two magnets into one of the nylon oval gears. The body incorporates a reed switch which senses the magnet passing. Lubricant entering the 55105 causes the gears to rotate. Each pulse equates to an approximate displacement of 0.040 cu. in. (0.65cc). The monitoring of the 55105 is done with any PLC. The feedback from the 55105 will assure that lubricant has reached the inlet of critical lubrication points.

APPLICATION

The 55105 Lube Point Monitor is intended to be mounted at or near the lubrication point inlet. It can be used with any type of grease or oil system (Dualine Progressive/PDI). Due to the nature of the internals, proper filtration is required to keep contaminants out of the monitor body.

TECHNICAL DATA

Flow	0-2500cc/min.	
Maximum Pressure	10153 psi (700 bar)	
Accuracy	±3%	
Vibrations	20 g (10-20000 Hz)	
Life Time	10 ⁹ pulses	
Temperature	-4°F to 158°F (-20°C to 70°C)	
Connections	1/8" NPT or 1/8 BSP	
Material	Aluminum or Stainless Steel	
Weight	0.186 kg	
Lubricant	ISO VG 32 Oil to NLGI Grade 2 Grease	
IP Enclosure Rating	IP67	
Connection	4-pole M12 x 1 (male)	
Switch Rating	Maximum Voltage	0-24 VDC
	Maximum Current	0.20 amp
How to Order	NPT	55105
	BSPP	55105-B
	NPT - SS	55105-SS
	BSPP - SS	55105-BSS

Refer to the following documents for more info:

- + Datasheet #35978: Lube Point Monitor
- + Datasheet #36973: DS405 Lubrication Monitor

SMAC-MAX Controller



(Alternating Current Voltage Model)

The SMAC-MAX Controller is a multi-purpose programmable controller used with industrial lubrication systems. Controller settings are saved whenever power is interrupted. Up to four operating modes can be selected which allows the controller to be used with various lubrication system designs. The controller is available in both 110 and 220 VAC service.

FEATURES

- + Digital status display on front cover for easy programming
- + System monitoring capabilities
- + Data memory function initiated at power down
- + 0-99 second afterblow
- + Monitoring of low pressure switch
- + Remote reset/manual run
- + Compact design

Refer to the following documents for more info:

- + Datasheet #36830: SMAC-MAX Controller

SMDC Controller



SMDC CONTROLLER

(Direct Current Voltage Model)

The SMDC Controller is a multi-purpose programmable controller used with 12-24 VDC lubrication systems. Controller settings are saved whenever power is interrupted. Up to four operating modes can be selected which allows the controller to be used with various lubrication system designs. A voltage selector

switch is located inside the enclosure for both 12 and 24 VDC service.

FEATURES

- Digital status display on front cover for easy programming
- System monitoring capabilities (cycle switch & low level switch)
- Data memory function initiated at power down
- Compact design

TECHNICAL DATA

Operating Voltage	110 VAC or 220 VAC (50/60 Hz)
IP Enclosure Rating	IP-55 (Liquid tight connector)
Fault Relay Contacts	30 W (220 VAC)
Ambient Temperature	-4°F to 131°F (-20°C to 55°C)
Vibration	2G
Switch Input	5V/20mA
Weight	4 lbs (1.8 kg)
Electrical Fuse	5 amp (5x20)

HOW TO ORDER

Name	Description	Part #
SMAC-MAX Controller	110/115 VAC	42012-5
	220/230 VAC	42012-4

CONTROLLER STATUS LED'S

Power	Green
Lube Pump	Green
Line Spray	Green
Low Level	Red
Air Pressure Low	Red
Pause	Yellow
None Lit	No input power to controller

TECHNICAL DATA

Operating Voltage	12VDC, 24VDC (factory setting)	
IP Enclosure Rating	External terminal strip	IP47
	Liquid tight connector	IP67
Fault Relay Contacts	24 VDC, 1 amp	
Ambient Temperature	-4°F to 104°F (-20°C to 40°C)	

HOW TO ORDER

Name	Description	Part #
SMDC Controller	Controller with external terminal strip	33346ME
	Controller with liquid tight connector	33346E

CONTROLLER STATUS LED'S

Red Steady	Lubrication cycle
Yellow Steady	Alarm
Green Steady	Power supply on
None Lit	No input to controller

Refer to the following documents for more info:

- + Datasheet #46911: SMDC Controller

SC400 Controller

Part Number: SC400 or SC400CSA



The SC400 Controller is a full featured lubrication control, offering “two plus one” functionality: Two independent lubrication zones may be programmed with a single controller, plus control of one automatic reservoir fill system.

The SC400 Controller has the ability to operate a single pump and two zone valves (e.g. frequent/infrequent lubrication cycles) or two separate pumps (e.g. one oil pump & one grease pump). Each zone operates independently. (“Two zone” feature is not available for Dualine electric systems or for systems that require after blow).

For single zone systems, the SC400 Controller also offers two intervals (e.g. weekday /weekend). Using an external switch, the customer can quickly change lubrication intervals between two sets of off time. The SC400 also incorporates an automatic fill feature. The controller can activate a fill pump as needed to maintain proper fluid levels in the oil or grease reservoir.

TECHNICAL DATA

Input	85 to 265 VAC, 50/60 Hz	
Current Consumption	80 mA at 115 VAC (less load) 40 mA at 230 VAC (less load)	
Outputs	Pump	8 amp (85 to 265 VAC)
	Line A & B	8 amp (90 to 250 VAC)
Fault Relay Contacts	5 Amp	
Enclosure	IP56	
Ambient Temperature	14°F to 131°F (-10°C to 55°C)	
Vibration	2 g at resonant (3 axis)	
Permanent Memory	FLASH	
Length x Width x Height	12.3" x 9.2" x 5"	
Application Modes	Series Progressive Single Line Injector Dualine (Hydraulic Reversing Valve) Dualine (Electric Reversing Valve) Continuous	

Refer to the following documents for more info:
+ Datasheet #35980 SC400 Controller

Timers

TIMER AND SOLENOID VALVE FOR PNEUMATIC OPERATED PUMPS

A compact timer which mounts directly to a solenoid valve having DIN 43650 Form A electrical terminations. Unit has four operating modes, with eight time ranges. Final time range settings are adjusted by potentiometers. Two red light emitting diodes indicate power 'ON' and output energized (solenoid 'ON').

TECHNICAL DATA (SOLENOID VALVE)

3-Way-2-Position - Normally Closed
1/8" NPT Ports
150 psi Max

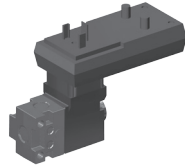

HOW TO ORDER

Name	Voltage	Part Number
Timer w/Dials	24-240 V AC/DC	29927
Timer Digital	24-240 V AC/DC	71740
	110/120 VAC 50/60 Hz	20311-3
Solenoid Valve	220/230 VAC 50/60 Hz	20311-4
	24 VDC	20311-7

Note: Order Timer and Solenoid separate.

Strainers

LS Strainers

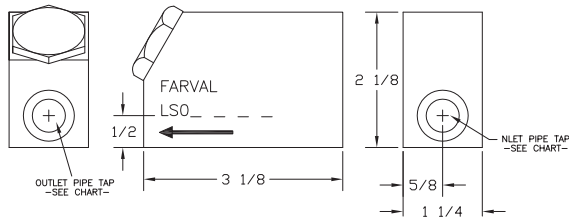

1. LS Line Strainers remove foreign particles from grease and oil lines in lubricating systems. Withstand up to 5000 psi working pressure non-shock.
2. Flow rate and ratio of open screen area to pipe diameter are:

Size (NPT)	Flow Rate (GPM)*	Ratio of Open Screen Area/Pipe Dia.	
		Perforated Metal Screen Type (500 Micron)	Wire Mesh Screen Type (75 & 150 Micron)
1/4	2	6:1	7:1
3/8	5	3.5:1	4:1

Note*: Based on 225 SSU oil at 100°F and 20 ft/sec. velocity.

REPLACEMENT SCREENS

Description	Part #
25 Micron Screen (Oil Only Up To 500 SSU)	LS0205103
150 Micron Screen (Oil Only Up To 2000 SSU)	LS0205106
500 Micron Screen (Oil Over 2000 SSU & All Grease)	LS0205120

TECHNICAL DATA (TIMER — PART #29927 & 71740)

Supply Voltage	24-240V AC/DC
Power Consumption	4 mA max
Switching Load	1 max = 0.5 A at supply voltage 110/230v, 50/60 Hz / (1.5A for 24 VDC)
Classification	IP65, air gaps and leakage paths according to VDE 0100
Body Material	Polyamide plastic
Working Temp. Range	14°-122°F (-10°-50°C)
Indicator	LED
Adjustment	29927 dial knobs 71740 keypads
Time Range - ON TIME	29927: 2 secs to 40 secs 71740: 0.5 secs to 99 secs
Time Range - OFF TIME	29927: 0.5 min to 45 min 71740: 0.5 min to 99 min

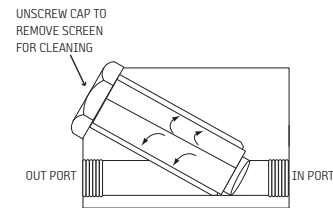

HOW TO ORDER

TYPICAL ORDERING CODE:
LS STRAINER (Part Number: LS02103)

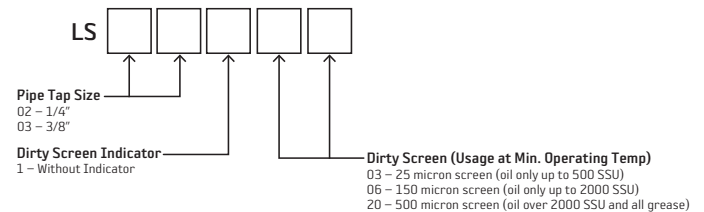

Refer to the following documents for more info:
+ Datasheet #36985: LS Strainers

Innovators of engineered lubrication technology **since 1872**

Bijur Delimon International has ISO 9001:2015 and ISO 14001:2015 quality certified manufacturing facilities around the world, so your centralized lubrication system meets the highest industry quality standards. It's all part of our commitment to quality and customer service.



BIJUR DELIMON
NORTH AMERICA
2685 Airport Road
Kinston, NC 28504

(252) 527 6001 **LOCAL**
(800) 227 1063 **TOLL-FREE**
(252) 527 3533 **FAX**

WWW.BIJURDELIMON.COM

SL2800 • R37 07/24